

SAPPMA Quality Workshop II

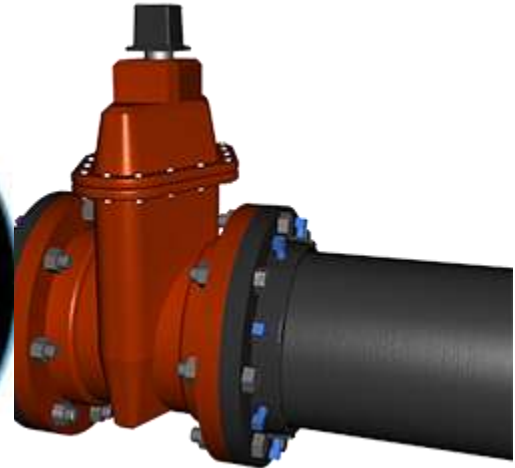

Co-presented by Justin Marsberg and Francois Prinsloo

Ian Venter

17-07-2019



Polymer and Plastics
Testing Laboratory



SAPPMA Quality Workshop II

SAPPMA quality Workshop				
	Starting times	Duration	Who	What
8:00	Setup	30	SAPPMA/ALS/Plastics SA	
8:15				
8:30	Registration Coffee Tee	30	SAPPMA	
8:45				
9:00	Welcome	5-10	Jan Venter	SAPPMA Introduction to PESC/ Break away groups for discussions
9:15	Raw materials	30-45	Ian Venter	
9:30				
9:45	QA			Pipes
10:00	Pipes	60	PESC	
10:15				
10:30				
10:45	QA			
11:00	Tea Break	15		
11:15	Fittings	45	Ian Venter	
11:30				
11:45	Systems			
12:00	QA			
12:15	Conformance assessment		PESC	
12:30				
12:45	QA			Lunch announcement /Break away Groups
13:00	Lunch			
13:15				
13:30	Break away groups for discussion		PESC	SAPPMA
13:45			Room 1	Room 2
14:00			Testing and related	Quality and Related
14:15				
14:30				
14:45				
15:00				

Ian Venter

17-07-2019

Pressure Pipe Systems; Raw Materials



Ian Venter
17-07-2019

Series Standards PE & PVC

ISBN 978-0-626-20747-2

SANS 4427-1:2008

Edition 1

ISO 4427-1:2007

Edition 1

SOUTH AFRICAN NATIONAL STANDARD

**Plastics piping systems — Polyethylene (PE)
pipes and fittings for water supply**

Part 1: General



**INTERNATIONAL
STANDARD**

**ISO
1452-1**

First edition
2009-12-01

**Plastics piping systems for water supply
and for buried and above-ground
drainage and sewerage under pressure —
Unplasticized poly(vinyl chloride)
(PVC-U) —**

**Part 1:
General**

Series Standards PE & PVC

ISO 4427 consists of the following parts, under the general title *Plastics piping systems — Polyethylene (PE) pipes and fittings for water supply*:

- *Part 1: General*
- *Part 2: Pipes*
- *Part 3: Fittings*
- *Part 5: Fitness for purpose of the system*

ISO 1452 consists of the following parts, under the general title *Plastics piping systems for water supply and for buried and above-ground drainage and sewerage under pressure — Unplasticized poly(vinyl chloride) (PVC-U)*:

- *Part 1: General*
- *Part 2: Pipes*
- *Part 3: Fittings*
- *Part 4: Valves*
- *Part 5: Fitness for purpose of the system*

Guidance for the assessment of conformity is to form the subject of a part 7.

System and component standard

BRITISH STANDARD

BS EN
805:2000

Water supply — Requirements for systems and components outside buildings



Reliable and safe supply of water for human consumption

Introduction

In specifying the requirements of this standard due regard has been taken of the importance of a reliable and safe supply of water for human consumption as well as for the purpose of trade, industry, agriculture and fire-fighting.

The widely varying water supply legislative requirements, populations, social and climatic conditions across Europe have also been taken into account.

This standard does not make any implication with regard to ownership of or responsibility for pipes or other apparatus in the supply system



The Standard Specifies

1 Scope

This standard specifies:

- general requirements for water supply systems outside buildings (see Figure 1), including potable water mains and service pipes, service reservoirs, other facilities and raw water mains but excluding treatment works and water resources development;
- general requirements for components;
- general requirements for inclusion in product standards which may include specifications which are more stringent;
- requirements for installation, site testing and commissioning.

The requirements of this standard apply to:

- the design and construction of new water supply systems;
- the extension of significant areas forming a coherent part of an existing water supply system;
- significant modification and/or rehabilitation of existing water supply systems.

Aspects that will influence the material selection and life expectancy of the material

Gene Pool

- Polymer morphology
- Additivation

Environment

- External temperature
- UV irradiation
- Installation conditions

Life Style

- Aggressive media
- Pressure, excessive stress
- Media temperature

Unforeseen

- External damage
- Violence
- Natural disaster

The Life Time Pipes is Determined by 3 Ageing Mechanisms

- Mechanical creep
- Crack growth
- Thermo-oxidative ageing

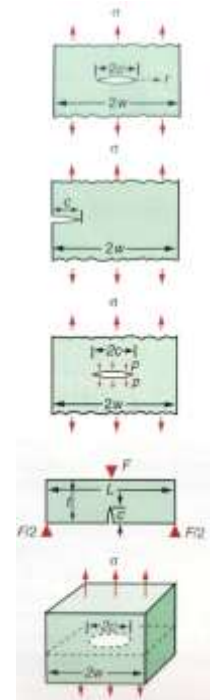

The velocity of the ageing mechanisms depends on temperature and loading. There is a “race” between these mechanisms. Under given conditions the “quickest” one is leading to failure!

Temperature Range

- Pipelines shall be designed for continuous operation over the anticipated temperature range of the water to be supplied. Loads arising from any temperature difference between installation and operation shall be taken into account. Attention shall be paid to the effects from external temperature conditions.

Temperature derating PE

- Temperature dependence of PE The temperature dependence of PE is given in SANS ISO 4427
- NOTE 1 For other temperatures between each step a linear interpolation is allowed. The coefficients mentioned are valid for PE 80 and PE 100. For other PE types see ISO 13761 [6]. NOTE 2 Unless analysis according to EN ISO 9080 demonstrates that less reduction is applicable, in which case higher factors and hence higher pressures can be applied.

Temperature [°C]	f_t
20	1,0
30	0,87
40	0,74



Temperature derating PVC

- Temperature dependence of PVC For PVC-O the same values can be used as for PVC-U (EN 1452-2).
- Pressure rating for PVC

Temperature [°C]	f_t
25	1,0
30	0,9
35	0,8
40	0,7
45	0,6



19 % change of temperature

From 23.0 °C to 27.6 °C 30 year Reduction

Case 2: Solve for Pressure rating		
OD=	450	Outside diameter, mm
SDR=	11	Standard dimension ratio
e=	40.9	Wall thickness, mm
σ =	8	Hoop stress, N/mm ²
D _m =	409.1	Mean diameter, mm
TF=	0.961538	Temperature factor
EF=	1	Environmental factor
LF=	1.04	Life expectancy factor
PN=	16.0	Nominal pressure, bar

Soil Temperature Profile

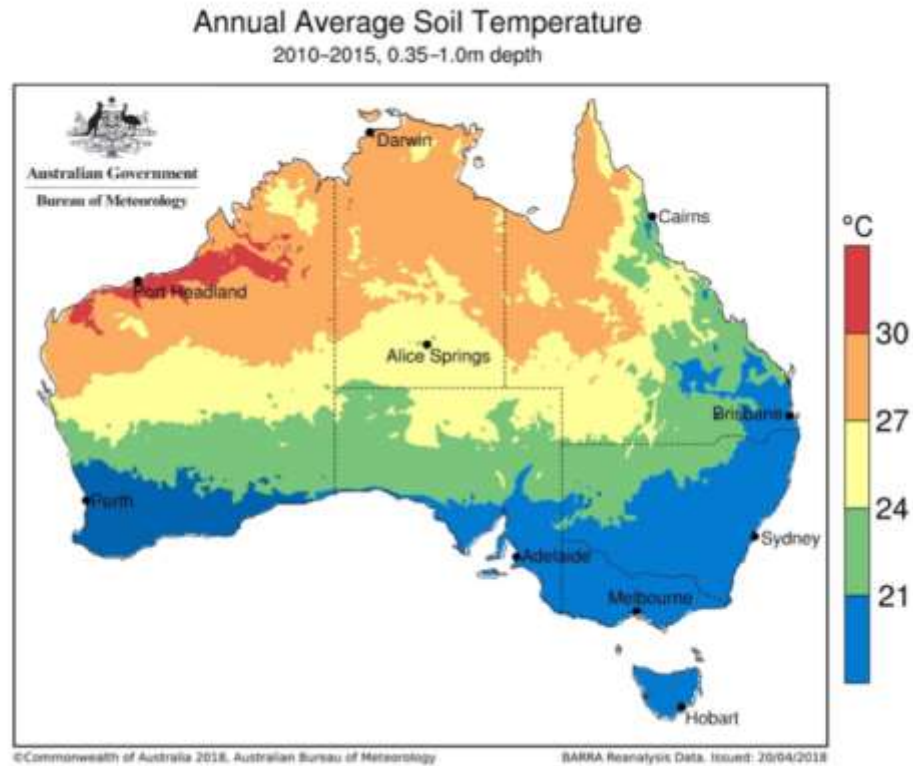

Figure 1 – Annual Average Soil Temperature

Unbalanced Thrust

- Forces are exerted at valves, changes in direction and diameter, branches and blank ends. These forces shall be compensated by an adequate number of restrained joints, thrust blocks or other anchorages.
- Where thrust blocks are to bear against the soil the safe bearing pressure shall be determined. The possibility of shear failure, sliding and potential disturbance of the thrust block by subsequent excavation shall be considered.

General requirements for Product Standards

- General Water supply components shall be capable of withstanding all conditions for which they have been designed, when used in water supply systems as defined in clauses 3 to 8 of the standard.
- All components shall conform with the relevant national product standards, transposing ENs as available, or with European Technical Approvals. The components shall be marked accordingly, including where appropriate the CE marking of conformity with the essential requirements of the Construction Products Directive or EFTA regulations where applicable.
- The product standard and technical approvals shall at least include the requirements specified in clause 9 and any other requirement necessary to ensure fitness for purpose in the field of water supply. The product standards shall also specify the appropriate test methods (type tests and/or quality tests) to ensure compliance with these requirements.
- Product standards shall specify any further relevant information not given in this standard regarding transport, storage, installation and maintenance.

General requirements for Product Standards

- Product standards shall be used for evaluating a product. In the absence of a product standard, this standard shall be used as a reference for the establishment of a specification (e.g. for European Technical Approval).
- This standard applies equally to components which are factory made and to those constructed in situ.
- The properties of the materials and components and their durability shall be defined and tested including their time-dependent degradation (see also 9.9).
- Product standards shall give sufficient information to enable verification of fitness for purpose of the components.

Materials

- All materials used for components, including linings, coatings and seals, intended for water supply systems shall be suitable for such an application. They shall not cause any unacceptable deterioration of the quality of the water with which they come into contact.

Validated Design Parameters

Plastics piping systems - Validated design parameters of buried thermoplastics piping systems

Introduction In Europe several design methods exist and some are still under development.

The plastics pipes industry has carried out a lot of research with full-scale trials.

From these research graphs have been made that shows the deflection in the pipes immediately after installation.

Also the so-called settlement period is measured. This settlement will always take place.

In case that heavy traffic is present, the final deflection will be reached faster.

It is strongly advised to check any calculated deflection with the values in the two design graphs. The information compiled is meant to be used by designers. The values given are meant for general guidance.

Validated Design Parameters

This document covers thermoplastics pipe material related properties and design topics to be taken into account when carrying out any static pipe calculation.

It also provides guidance to applying structural design of thermoplastics piping systems for pressure and non-pressure applications. It furthermore provides documentation based on long term experience, to be used in justifying and / or verification of any structural design method.

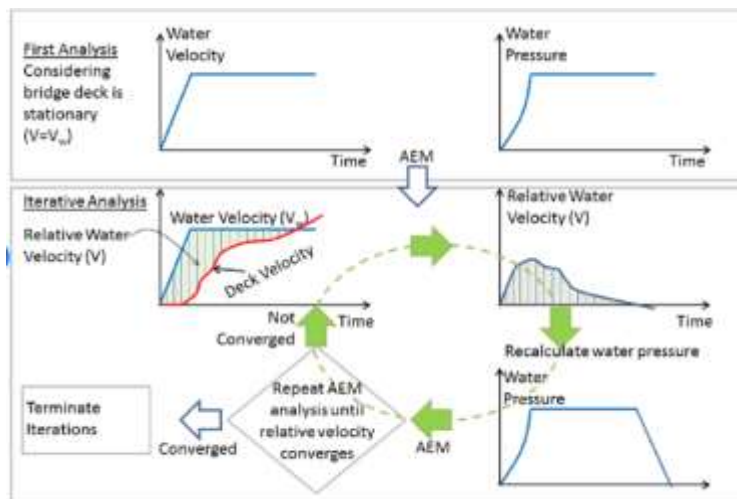

Typical Material properties

Plastics pipe properties related to design are given in Table 1.

Table 1 — Material properties: values ^a typical for calculations

Material	Poisson ratio [-]	Coefficient of linear expansion [1/ °C]	Young's modulus [MPa]	Relaxation coefficient [-]	Tensile strength [MPa]
PVC-HI	0,4	6×10 ⁻⁵	2 500	0,06	40
PVC 250	0,4	8×10 ⁻⁵	3 200	0,05	50
PVC 315	0,4	8×10 ⁻⁵	3 500	0,05	60
PVC 355	0,4	8×10 ⁻⁵	3 500	0,05	60
PVC 400	0,4	8×10 ⁻⁵	3 500	0,05	60
PVC 450	0,4	8×10 ⁻⁵	3 500	0,05	60
PVC 500	0,4	8×10 ⁻⁵	3 500	0,05	60
PE 63	0,45	19×10 ⁻⁵	800	0,06	17
PE 80	0,45	19×10 ⁻⁵	850	0,07	19
PE 100	0,45	19×10 ⁻⁵	1 100	0,08	21
PP-B	0,42	12×10 ⁻⁵	1 250	0,07	27
PP-HM	0,42	12×10 ⁻⁵	1 700	0,07	31
PP-H	0,42	12×10 ⁻⁵	1 250	0,07	30
PP-R	0,42	12×10 ⁻⁵	950	0,07	23

^a If specific values are needed related to specific products, these shall be acquired from the manufacturer or specific standards.

Minimum Required Strength MRS

Pressure pipes (stress design basis)

Minimum Required Strength (MRS)

The minimum required strength shall be classified according to EN ISO 12162.

The classification shall be determined out of the lower confidence limit tangential stress, which divides the MRS values into ranges.

In the pressure test according to EN ISO 9080 the LCL-value shall be determined for the pipe material.

This LCL-value gives the classification for the MRS value.

For classification reasons 50 year have been taken and the relevant design coefficient is applied. In practice the lifetime will be longer. Therefore also the remaining design factor 100 year is given. For the different thermoplastics materials used in buried pipes, the MRS values are given

Material Properties @ 20°C

Table 2 — Material properties relevant for pressure pipes at 20 °C

Material ^a	MRS σ classification [MPa]	Overall service design coefficient ^b C_{50} [-]	Overall design coefficient ^c C_{100} [-]	Allowable approximately one hour stress [MPa]
PVC-HI	18	1,4	1,38	35
PVC 250	25,0	2,0	1,94	42
PVC 315	31,5	1,6	1,58	45
PVC 355	35,5	1,6	1,58	51
PVC 400	40,0	1,6	1,58	57
PVC 450	45,0	1,4	1,38	64
PVC 500	50,0	1,4	1,38	71
PE 63	6,3	1,25	—	10
PE 80	8,0	1,25	1,23	12,6
PE 100	10,0	1,25	1,23	12,5
<p>^a If specific values are needed related to specific products, these shall be acquired from the manufacturer or specific standards.</p> <p>^b The overall design coefficient is determined in EN ISO 12162 and the values shown in the table are minimum values. The values may be increased by users when specific fluids which are harmful for the environment or mankind.</p> <p>^c Based on regression curves it is shown that the C_{100} coefficients slightly differ from the C_{50} values.</p>				
<p>NOTE At temperatures below 20 °C the values will be higher than those shown.</p>				

Classification and Designation

Overall service (Design) coefficient (Service Factors)

INTERNATIONAL
STANDARD

ISO
12162

First edition
1995-06-01

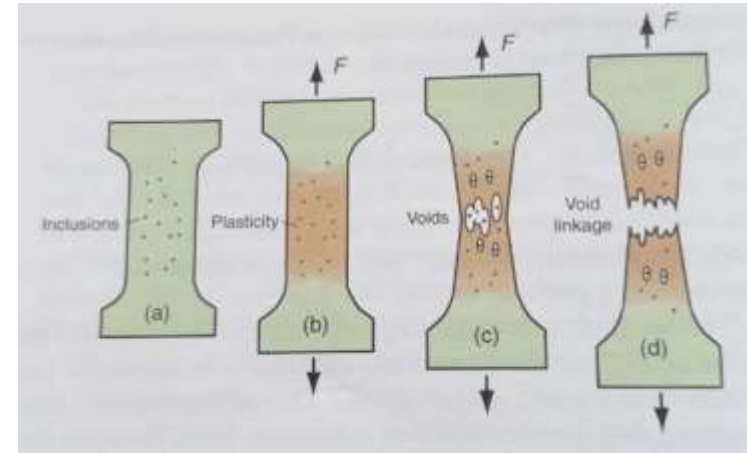

Thermoplastics materials for pipes and fittings for pressure applications — Classification and designation — Overall service (design) coefficient

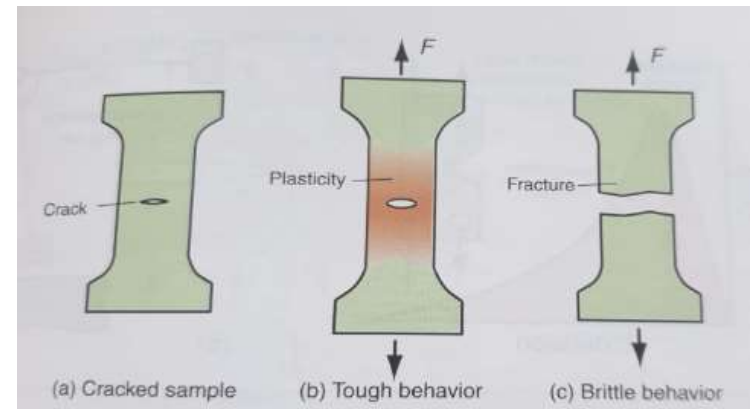

Service Factors

Introduction

ISO/TR 9080 states in 0.2.7 of its introduction that methods for using σ_{LTHS} and/or σ_{LCL} to arrive at the allowable design stresses still had to be considered. Service factors or safety factors have to be introduced.

This International Standard uses the lower confidence limit of the long-term strength, σ_{LCL} , as a basis for material classification and designation and defines the relation with the design stress. The service factors are expressed in the overall service (design) coefficient. The final overall service (design) coefficients are given in the product or system standards.

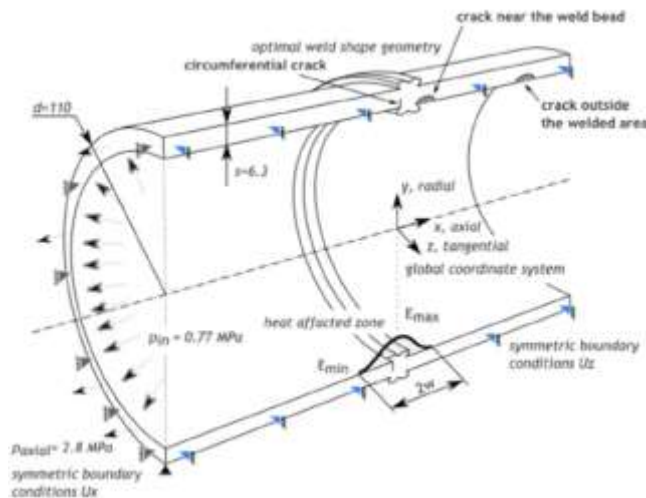

ISO 12162 Part of Pressure Pipe Standards

This international Standard establishes the classification of thermoplastics materials in pipe form and specifies the material designation.

It also gives a method for calculating the design stress.

It applies to materials intended for pipes and/or fittings for pressure applications.

The classification, the material designation, and the calculation method are based on the resistance to internal pressure with water at 20°C in water for 50 years, derived by extrapolation using the method given in SANS ISO/TR 9080

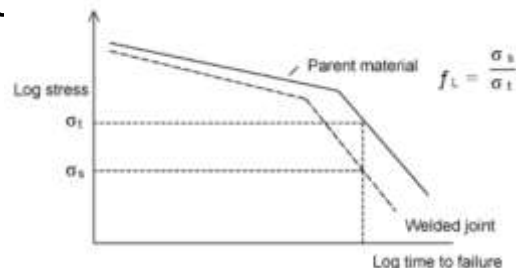

Definition long-term strength at 20 °C for 50 years

Long-term strength at 20 °C for 50 years, σ_{LTHS} :

Quantity with the dimensions of stress, in megapascals, which can be considered as a property of the material and represents the 50 % lower confidence limit for the long-term strength. It is equal to the mean strength or predicted mean strength at 20 °C for 50 years with internal pressure with water.

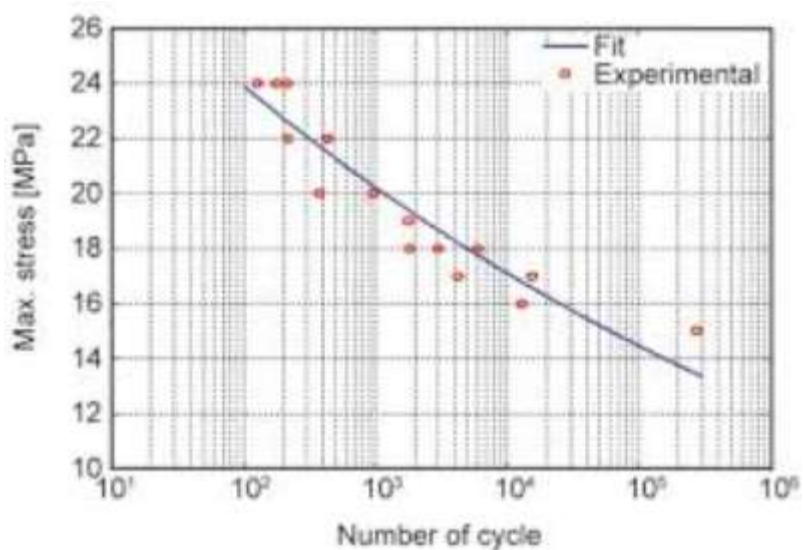

Definition lower confidence limit at 20 °C for 50 years

- lower confidence limit at 20 °C for 50 years, σ_{LCL} : Quantity with the dimensions of stress, in megapascals, which can be considered as a property of the material and represents the 97,5 % lower confidence limit of the mean long-term strength at 20 °C for 50 years with internal pressure with water.

Definition minimum required strength MRS

- minimum required strength, MRS:
Value of σ_{LCL} , rounded down to the next smaller value of the R10 series or of the R20 series conforming to
- ISO 3 and ISO 497, depending on the value of σ_{LCL} .



Classification MRS (MPa)

Table 1 — Classification

Range of lower confidence limits σ_{LCL} MPa	Minimum required strength MRS MPa	Classification number ¹⁾
$1 \leq \sigma_{LCL} \leq 1,24$	1	10
$1,25 \leq \sigma_{LCL} \leq 1,59$	1,25	12,5
$1,6 \leq \sigma_{LCL} \leq 1,99$	1,6	16
$2 \leq \sigma_{LCL} \leq 2,49$	2	20
$2,5 \leq \sigma_{LCL} \leq 3,14$	2,5	25
$3,15 \leq \sigma_{LCL} \leq 3,99$	3,15	31,5
$4 \leq \sigma_{LCL} \leq 4,99$	4	40
$5 \leq \sigma_{LCL} \leq 6,29$	5	50
$6,3 \leq \sigma_{LCL} \leq 7,99$	6,3	63
$8 \leq \sigma_{LCL} \leq 9,99$	8	80
$10 \leq \sigma_{LCL} \leq 11,19$	10	100
$11,2 \leq \sigma_{LCL} \leq 12,49$	11,2	112
$12,5 \leq \sigma_{LCL} \leq 13,99$	12,5	125
$14 \leq \sigma_{LCL} \leq 15,99$	14	140
$16 \leq \sigma_{LCL} \leq 17,99$	16	160
$18 \leq \sigma_{LCL} \leq 19,99$	18	180
$20 \leq \sigma_{LCL} \leq 22,39$	20	200
$22,4 \leq \sigma_{LCL} \leq 24,99$	22,4	224
$25 \leq \sigma_{LCL} \leq 27,99$	25	250
$28 \leq \sigma_{LCL} \leq 31,49$	28	280
$31,5 \leq \sigma_{LCL} \leq 35,49$	31,5	315
$35,5 \leq \sigma_{LCL} \leq 39,99$	35,5	355
$40 \leq \sigma_{LCL} \leq 44,99$	40	400
$45 \leq \sigma_{LCL} \leq 49,99$	45	450
$50 \leq \sigma_{LCL} \leq 54,99$	50	500

1) If the classification number is not an integer, a full stop is used instead of a comma.

Material
PVC-HI
PVC 250
PVC 315
PVC 355
PVC 400
PVC 450
PVC 500
PE 63
PE 80
PE 100
PP-B
PP-HM
PP-H
PP-R

Definition Overall service (design) Coefficient C

- Overall coefficient with a value greater than 1, which takes into consideration service conditions as well as properties of the components of a piping system other than those represented in the lower confidence limit.
- NOTE 1 Minimum values of C for various materials are given

Overall service (Design) Coefficients (Minimums)

Table 2 — Minimum values of C

Material	C min.
ABS	1,6
PB	1,25
PE (all types)	1,25
PE-X	1,25
PP copolymer	1,25
PP homopolymer	1,6
PVC-C	1,6
PVC-HI	1,4
PVC-U	1,6
PVDF copolymer	1,4
PVDF homopolymer	1,6

Designation of materials in pipe form

Designation of materials in pipe form

- The designation shall be given by a combination of the following:
- the symbol of the material in accordance with ISO 1043-1 ;
- its classification number in accordance with clause 4.
- EXAMPLE
- A PVC-U with an MRS of 25 MPa is designated as follows:
- PVC-U 250

Definition of Design Stress

- σ_s Allowable stress for a given application. It is derived by dividing the MRS by the coefficient C, then rounding to the next lower value in the R20 series, i.e.

$$\sigma_s = \frac{[MRS]}{C}$$



MRS reduction effect on Static Pressure Capabilities PE 100

PE100 = MRS 10 with a C of 1.25 for Potable water @ 20°C ($\sigma_s = 8 \text{ Mpa}$)
 Below shows the effect of using non conforming materials on life expectancy

Case 2: Solve for Pressure rating

OD=	63	Outside diameter, mm	
SDR=	11	Standard dimension ratio	
e=	5.7	Wall thickness, mm	
σ =	7.48	Hoop stress, N/mm ²	0.52
D _m =	57.3	Mean diameter, mm	6.5%
TF=	1	Temperature factor	
EF=	1	Environmental factor	
LF=	1.07	Life expectancy factor	
	10	years	
PN=	16.0	Nominal pressure, bar	
w=	1.05	pipe weight, kg/m	
SDR=	11.0	Standard dimension ratio	
S=	5.0		

$$P = \frac{20 \cdot e \cdot \sigma}{D_m}$$

Case 2: Solve for Pressure rating

c

OD=	63	Outside diameter, mm	
SDR=	11	Standard dimension ratio	
e=	5.7	Wall thickness, mm	
σ =	7.69	Hoop stress, N/mm ²	0.31
D _m =	57.3	Mean diameter, mm	3.9%
TF=	1	Temperature factor	
EF=	1	Environmental factor	
LF=	1.04	Life expectancy factor	
	20	years	
PN=	16.0	Nominal pressure, bar	
w=	1.05	pipe weight, kg/m	
SDR=	11.0	Standard dimension ratio	
S=	5.0		

$$P = \frac{20 \cdot e \cdot \sigma}{D_m}$$

Questions and Answers



SAPPMA Quality Workshop II Pressure Pipes

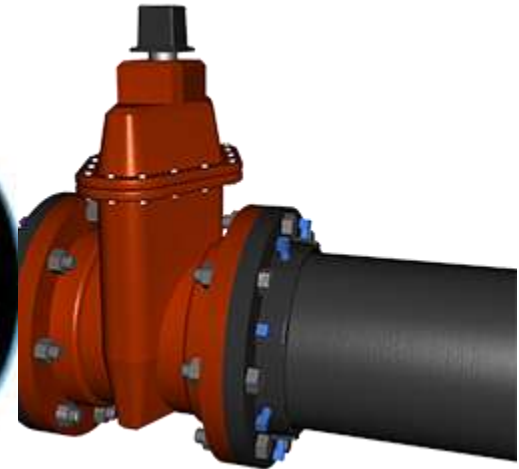

Co-presented by Justin Marsberg and Francois Prinsloo

Ian Venter

17-07-2019



Polymer and Plastics
Testing Laboratory



Pressure Pipe Systems; Pressure Pipes



Ian Venter
17-07-2019

Requirements for water supply systems

Water quality

- The water quality in the potable water supply system shall satisfy the requirements of national legislation

Materials

- All parts of water supply systems in contact with potable water shall be designed and constructed using components and materials which meet the appropriate requirements such that there is no unacceptable deterioration of water quality.



Series Standards PE & PVC

Introduction

ISO 4427, the system standard, specifies the requirements for a piping system and its components when made from polyethylene (PE). The piping system is intended to be used for water supply intended for human consumption, including the conveyance of raw water prior to treatment and that of water for general purposes.

In respect of potential adverse effects on the quality of water intended for human consumption caused by the products covered by ISO 4427:

- a) ISO 4427 provides no information as to whether the products may be used without restriction;
- b) existing national regulations concerning the use and/or the characteristics of these products are in force.

NOTE Guidance for assessment of conformity can be found in Bibliographical references [9] and [10].

Introduction

The System Standard, of which this is Part 1, specifies the requirements for a piping system and its components made from unplasticized poly(vinyl chloride) (PVC-U). The piping system is intended to be used for water supply and for buried and above-ground drainage and sewerage under pressure.

In respect of potential adverse effects on the quality of water intended for human consumption, caused by the products covered by this part of ISO 1452, the following are relevant.

- a) This part of ISO 1452 provides no information as to whether or not the products can be used without restriction.
- b) Existing national regulations concerning the use and/or the characteristics of these products remain in force.

Requirements and test methods for components are specified in ISO 1452-2, ISO 1452-3 and ISO 1452-4. Characteristics for fitness for purpose (mainly for joints) are established in ISO 1452-5.

This part of ISO 1452 specifies the general aspects of PVC-U.

Guidance for installation is given in ISO/TR 4191^[1].

Guidance for assessment of conformity is provided in ENV 1452-7^[2].

Interconnection of pipes

The interconnection of potable water supply systems shall only be permitted if the chemical and physical properties are compatible for blending and there is no unacceptable deterioration of water quality. Except when water is intended for blending in the distribution system to produce a potable supply, there shall be no direct connection between potable water supply systems and systems containing non-potable water,

Pipe Sizing

Mains and service pipes shall be sized to meet the maximum specified flow rate having regard to the defined levels of service.

In determining the required capacity of a service reservoir the balance between supply and demand shall be taken into account.



Sizing continue

In addition, other aspects shall be considered including, but not limited to, the following:

- estimated time to repair burst main upstream;
- effect of pump/power failure;
- existence of alternative sources of supply;
- single or duplicate supply mains to storage;
- degree of telemetry monitoring;
- ratio of peak hour to average flow rate;
- requirements with respect to water for industrial supplies, fire-fighting or other special circumstances.

Hydraulic calculation

Hydraulic calculation shall be carried out in order to demonstrate that the system will:

- satisfy the estimated demand;
- operate at acceptable velocities;
- operate within the required pressure range.

In addition, the design pressure and the maximum design pressure shall be established at appropriate points in the system.

The required diameters to satisfy the flow requirements for the hydraulic gradient available shall be verified

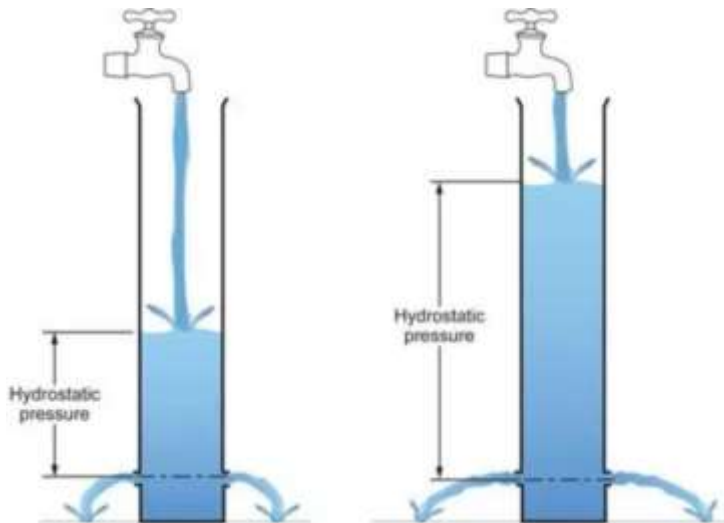

Service Pipes Domestic Consumers

Service pipes

Domestic consumers

The diameter of service pipes for domestic purposes shall be determined on the basis of the levels of service requirements' including service pressure and flow rate. Head losses through all components including fittings and meters shall be taken into consideration

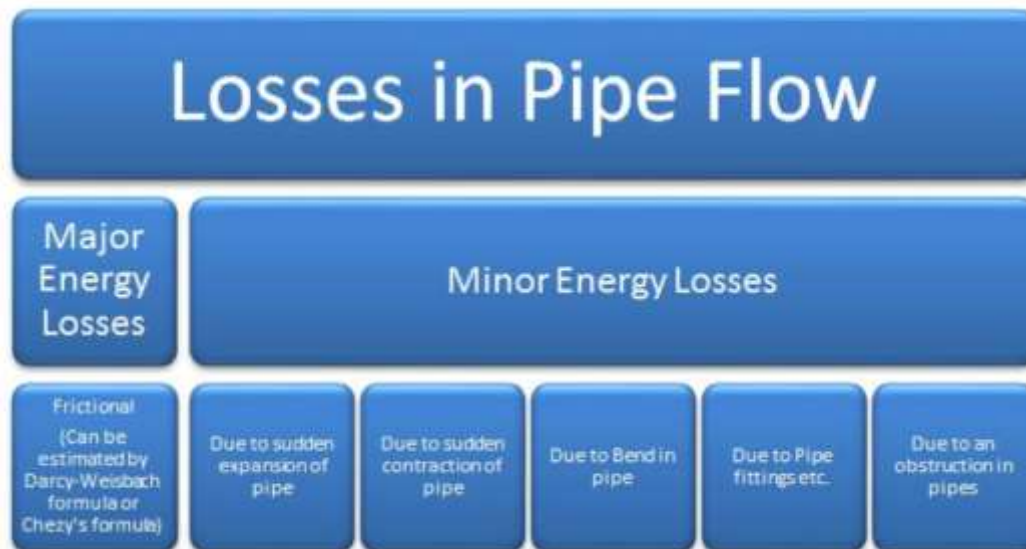

Designation of pressure

Table 1 - Designation of pressures in English, French and German

Abbreviation ^a	English	French	German	
DP	design pressure	pression de calcul en régime permanent	Systembetriebsdruck	System related
MDP	maximum design pressure	pression maximale de calcul	höchster Systembetriebsdruck	
STP	system test pressure	pression d'épreuve du réseau	Systemprüfdruck	
PFA	allowable operating pressure	pression de fonctionnement admissible	zulässiger Bauteilbetriebsdruck	Component related
PMA	allowable maximum operating pressure	pression maximale admissible	höchster zulässiger Bauteilbetriebsdruck	
PEA	allowable site test pressure	pression d'épreuve admissible sur chantier	zulässiger Bauteilprüfdruck auf der Baustelle	
OP	operating pressure	pression de fonctionnement	Betriebsdruck	System
SP	service pressure	pression de service	Versorgungsdruck	related
^a Valid for all language versions.				

Pressure Conditions for specifying components

Table 2 - Pressure conditions for specifying components

Components	System
PFA \geq	DP
PMA \geq	MDP
PEA \geq	STP
≥ 80 kPa below atmospheric pressure	≤ 80 kPa below atmospheric pressure

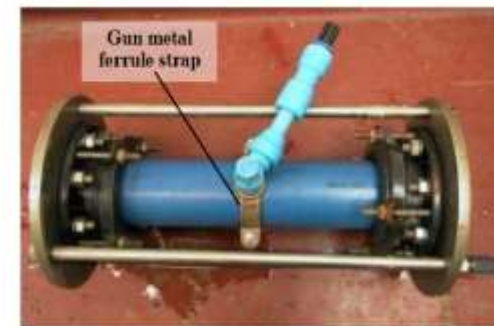

Figure 1, Test rig for gun-metal ferrule strap



Figure 2, Test rig for Hawle Ferrule strap

50 vs 100 year Design Life

- Design life Systems shall be designed for a life of at least 50 years. Some components such as pumps and certain metering and control equipment may require earlier renovation or replacement.

Tabelle A.5 — Zulässige Betriebsüberdrücke für
Rohre aus PE 100, Durchflussmedium Wasser,
Gesamtbetriebs(berechnungs-)koeffizient $C = 1,25$

Table A.5 — Allowable working pressure for
pipes made of PE 100, conveying water,
overall service (design) coefficient $C = 1,25$

Temperatur Temperature °C	Betriebs- jahre Years of service	Rohrserie S Pipe series S													
		25	20	16	12,5	10,5	10	8,3	8	6,3	5	4	3,2	2,5	2
		Durchmesser/Wanddicken-Verhältnis SDR Standard dimension ratio SDR													
		51	41	33	26	22	21	17,6	17	13,6	11	9	7,4	6	5
Zulässiger Betriebsüberdruck Allowable working pressure bar															
20	5	3,3	4,2	5,3	6,6	7,8	8,4	10,0	10,5	13,3	16,7	21,0	26,5	33,4	42,0
	10	3,3	4,1	5,2	6,5	7,7	8,3	9,9	10,4	13,1	16,5	20,8	26,2	33,0	41,5
	25	3,2	4,0	5,1	6,4	7,5	8,1	9,7	10,1	12,8	16,1	20,3	25,6	32,2	40,5
	50	3,2	4,0	5,0	6,3	7,4	8,0	9,6	10,0	12,5	16,0	20,0	25,0	32,0	40,0
	100	3,1	3,9	4,9	6,1	7,3	7,8	9,4	9,8	12,3	15,5	19,5	24,6	31,0	39,0

Designation of Pressure

allowable maximum operating pressure (PMA)

maximum pressure occurring from time to time, including surge, that a component is capable of withstanding in service

allowable operating pressure (PFA)

maximum hydrostatic pressure that a component is capable of withstanding continuously in service

allowable site test pressure (PEA)

maximum hydrostatic pressure that a newly installed component is capable of withstanding for a relatively short duration, in order to ensure the integrity and tightness of the pipeline

design pressure (DP)

maximum operating pressure of the system or of the pressure zone fixed by the designer considering future developments but excluding surge

service pressure (SP)

internal pressure delivered at the point of connection to the consumer's installation at zero flow in the service pipe

Designation of Pressure continue

system test pressure (STP)

hydrostatic pressure applied to a newly laid pipeline in order to ensure its integrity and tightness

maximum design pressure (MDP)

maximum operating pressure of the system or of the pressure zone fixed by the designer considering future developments and including surge, where:

- MDP is designated MDPa, when there is a fixed allowance for surge;
- MDP is designated MDPc, when the surge is calculated

operating pressure (OP)

internal pressure which occurs at a particular time and at a particular point in the water supply system

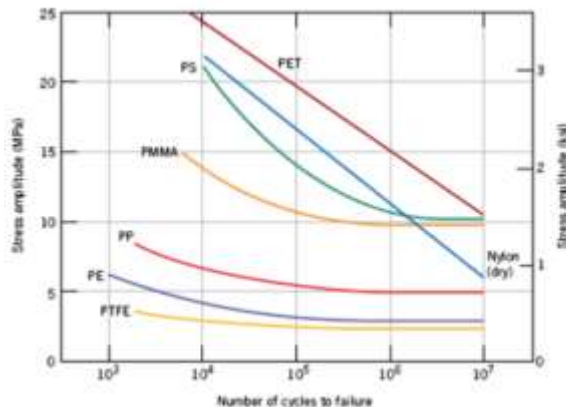

Flow Velocities

Surge

Rapid fluctuations of pressure caused by flow alterations over short periods of time

Flow velocities

Aspects to be considered in determining acceptable flow velocities shall at least include the following:

stagnation;
turbidity;
pressure;
surge;
pumping facilities.

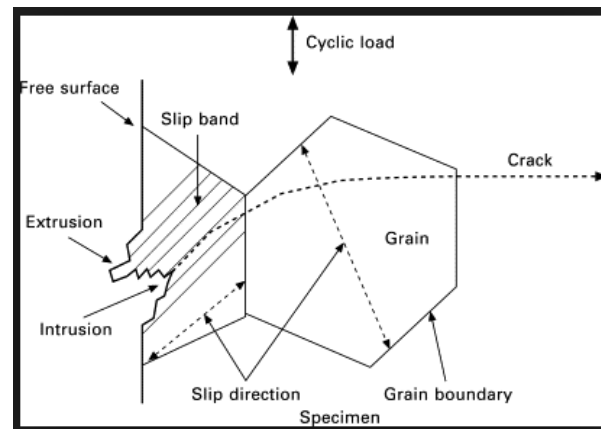

Surge Limiting Equipment

Surges can be generated following power failures, pump starting or stopping and valve operation. Consideration shall be given to the need for surge limiting equipment as part of a pumped or gravity system.



Direct acting valve



Pilot operated valve

Example of a pressurized gravity main

A.2 ad 3.1 Pressures

Surge is mainly related to flow velocity and not to internal pressure (see Figures A.1 and A.2).

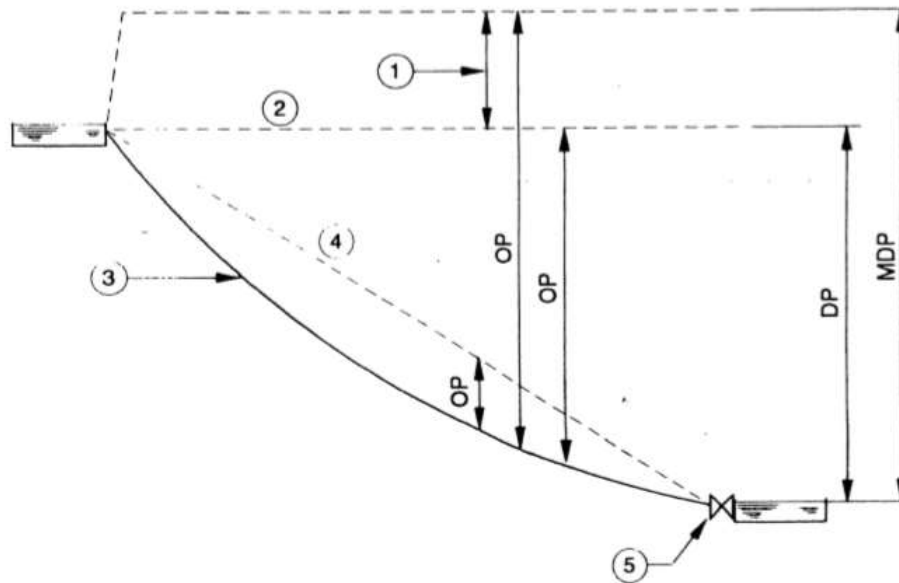

Key

- 1 Surge
- 2 No flow hydraulic gradient
- 3 Pipeline profile
- 4 Hydraulic gradient
- 5 Valve

Figure A.1 - Example of pressurized gravity main

Example of a Surge (Stress) wave

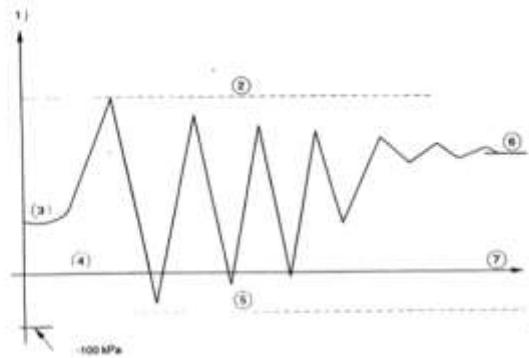

Key

- 1 Pressure
- 2 MDP (maximum design pressure)
- 3 Initial OP
- 4 Atmospheric pressure
- 5 Saturated vapour pressure
- 6 New OP
- 7 Time

Figure A.2 - Example of surge wave

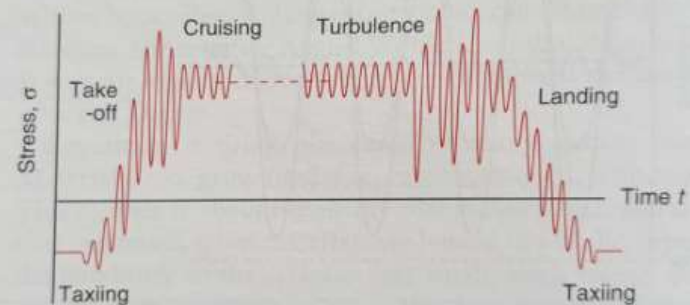
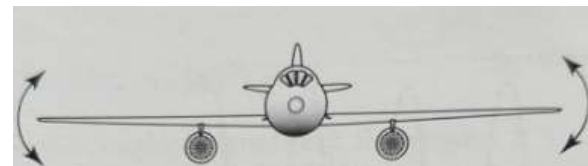
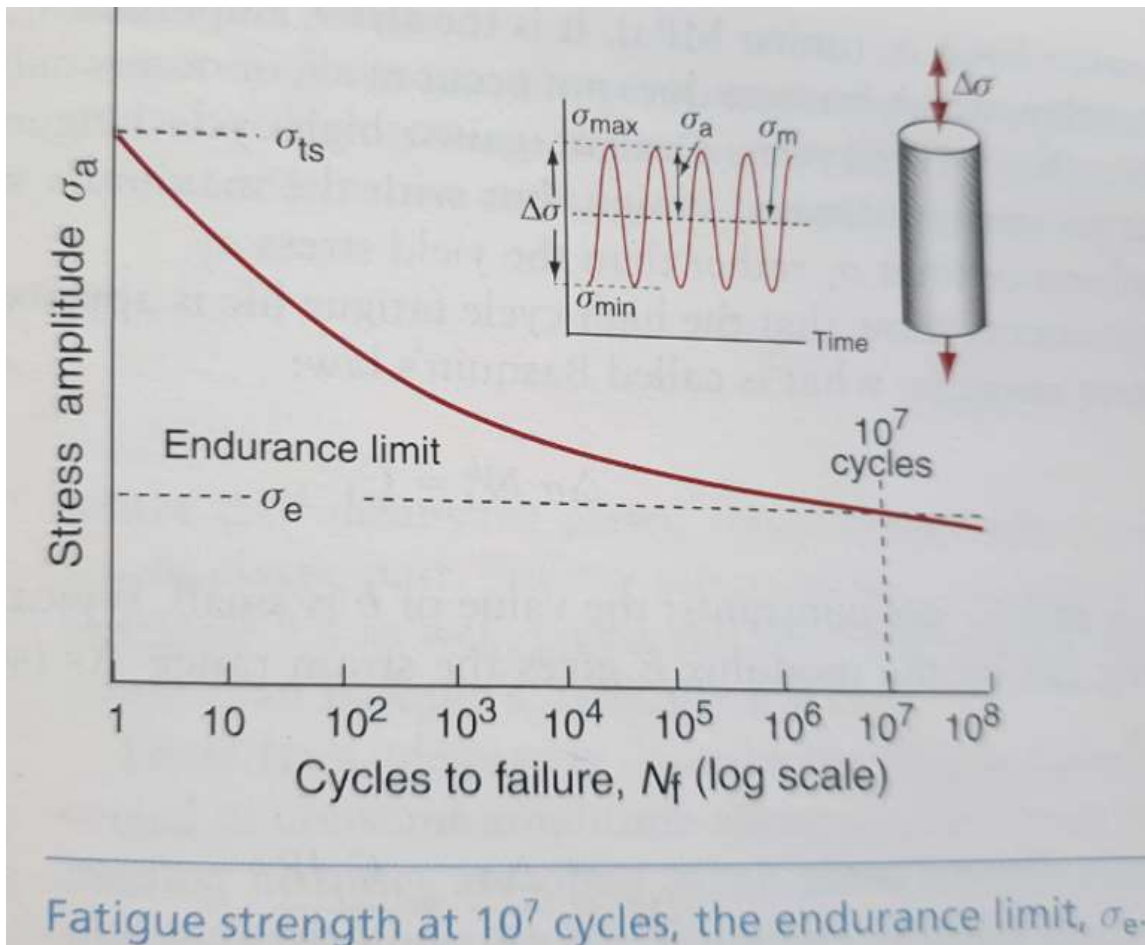

Figure 9.2 Schematic of stress cycling on the underside of a wing during flight.

Fatigue strength, Endurance Limit



Structural Design

Internal forces

- Pipelines shall be designed for maximum flow, no-flow and transient conditions. In the case of transient conditions the amplitude and frequency shall be estimated.
- Pipelines shall be designed to withstand a transient pressure of 80 kPa below atmospheric pressure (approximately 20 kPa absolute pressure).
- The design pressure and the maximum design pressure shall be determined. Test pressure shall be taken into consideration.

Structural Design

External forces

- The external forces to be taken into account shall include:
- backfill loads (vertical and horizontal forces due to earth load);
- surcharge;
- groundwater;
- transient loads;
- self-weight of the pipe and weight of the water at least for $DN \geq 1\ 000$;
- any other forces arising from installation or the consequences thereof including pipes on local supports.

Protection against aggressive environment

The designer shall assess potential damage due to contact with soils and various pollutants

The designer shall consider, with reference to product standards, appropriate measures to protect pipelines against undesired effects due to aggressive environments and the conveyed water.

The designer shall specify the method for the repair of coatings, linings and for any additional protection of joints.



Nominal Sizes

The size of the components shall be designated by the use of DN.

Within the size range given below the DN values shall be taken from either of the two following series

One relating to the internal diameter (DN/ID), the other to the external diameter (DN/OD).

Product standards shall indicate to which series they relate.

In South Africa we predominantly work with DN/OD (mm)

DN/OD: 25, 32, 40, 50, 63, 75, 90, 110, 125, 160, 180, 200, 225, 250, 280, 315, 355, 400, 450, 500, 630, 710, 800, 900, 1 000, 1 100, 1 200, 1 250, 1 300, 1 400, 1 500, 1 600, 1 800, 2 000, 2 100, 2 200, 2 400, 2 500

Product Standard

Product standards of components designated with DN/OD shall specify the external diameter, wall thickness and the relevant tolerances. Minus tolerances on the calculated internal diameter derived from the nominal values given in the product standard shall not exceed the values given in table 3.

Table 3 - Minus tolerances on the internal diameter

DN	Minus tolerance on mean mm	Minus tolerance on individual value mm
DN < 80	0,05 DN	0,1 DN
80 ≤ DN ≤ 250	5	10
250 < DN ≤ 600	0,02 DN	0,04 DN
DN > 600	15	30

Length and Wall thickness

Tolerances of wall thickness and lengths of components shall be specified in the product standards, irrespective of whether the wall thickness and/or length is given. If the wall thickness and/or length is not specified in the product standard, the product standard shall require the manufacturer to declare it.

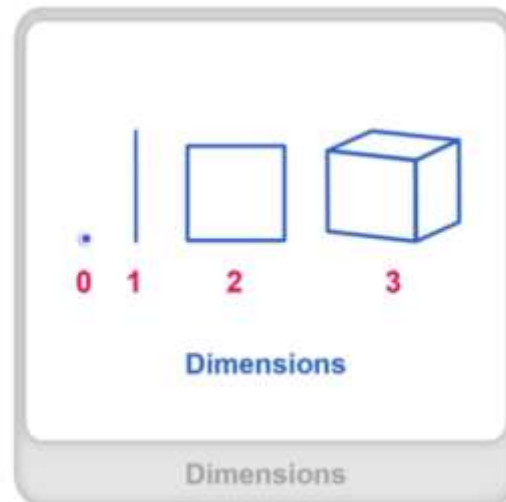

Wall thickness VS Life expectancy

Case 2: Solve for Pressure rating

OD=	63	Outside diameter, mm
SDR=	11	Standard dimension ratio
e=	5.7	Wall thickness, mm
σ =	8	Hoop stress, N/mm ²
D _m =	57.3	Mean diameter, mm
TF=	1	Temperature factor
EF=	1	Environmental factor
LF=	1	Life expectancy factor
	50	years
PN=	16.0	Nominal pressure, bar
w=	1.05	pipe weight, kg/m
SDR=	11.0	Standard dimension ratio
S=	5.0	

$$P = \frac{20 \cdot e \cdot \sigma}{D_m}$$

Case 2: Solve for Pressure rating

OD=	63	Outside diameter, mm
SDR=	11.66669	Standard dimension ratio
e=	5.4	Wall thickness, mm
σ =	8	Hoop stress, N/mm ²
D _m =	57.6	Mean diameter, mm
TF=	1	Temperature factor
EF=	1	Environmental factor
LF=	1.07	Life expectancy factor
	10	years
PN=	16.0	Nominal pressure, bar
w=	1.00	pipe weight, kg/m
SDR=	11.7	Standard dimension ratio
S=	5.3	

$$P = \frac{20 \cdot e \cdot \sigma}{D_m}$$

Geometry of pipes, fittings and valves

Geometry of pipes, fittings and valves Except in the case of pipes delivered in coils, pipes shall be straight, within tolerances specified in product standards. If pipes are delivered in coils, product standards shall specify a minimum radius of the coils.

The plane of the end faces of the pipes, fittings and valves shall be at 90° to the relevant axis with a tolerance such that the function of the pipe joint shall not be impaired.

Preferred angles for bends are 11° 1/4; 22° 1/2; 30°; 45° and 90°.



Internal Surface /Appearance and soundness

The internal surface of pipes, fittings and valves shall be free from visible defects that may affect their hydraulic performance. The product standard shall specify the acceptable imperfections.

Appearance and soundness

Components shall be of uniform condition. They shall not exhibit any damage or be affected in any way likely to impair their performance.

Although the industry in general allow a 10 % of wall thickness damage to PE100 pipes it is suggested that this gets specified down to 5%.

Scratches between 5 % and 10 % to be removed and section of pipe to be replaced.

Structural design

Structural design Product standards shall indicate the relationship between the pressures they specify and PFA, PMA and PEA.

The structural design of components shall take into account all the relevant factors for their safe and reliable operation in water supply systems as described in the standard, as well as:

the maximum and minimum operating temperatures, and temperature-induced loads, the effects of sustained long term loading on the material properties (e.g. creep, static fatigue);

the effects of dynamic loading on the material properties (e.g. dynamic fatigue);

the effects of potential hazards such as ground movements and/or earthquakes.

Components shall be designed to withstand, when installed, a transient pressure of 80 kPa below atmospheric pressure (approximately 20 kPa absolute pressure).

Maximum Long term Deformation

The maximum allowable long term deflection shall not exceed 8 %.
Product standards shall give sufficient information in accordance with EN 1295-1 to enable structural design.

The designer will specify the Maximum Short Term Deformation MSTD allowable for the product based on the workmanship and pipe stiffness as referenced in the TEPFFA buried pipe design guideline.

This needs to take into account the functionality of the joint under the circumferential and angular deflected state.

A suggestion will be to determine this MSTD compliance within the first three days after final compaction

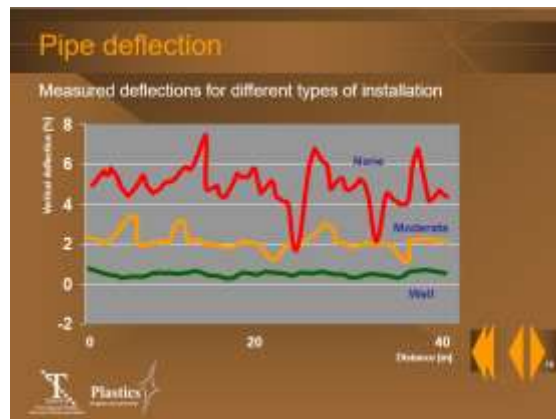

Pressure Fluctuations

Pressure fluctuations in pumped mains result from events such as pump start-up and shutdown or valves opening and closing. The approach adopted for pipe design and class selection when considering these events depends on the anticipated frequency of the pressure fluctuation as follows:

- for random, isolated surge events, for example, those which result from emergency shutdowns, the designer must ensure that the maximum and minimum pressures experienced by the system are within acceptable limits; and
- for frequent, repetitive pressure variations, the designer must consider the potential for fatigue and design accordingly.



Figure 1 : Pressure Cycle

Pressure terminology

- For the purposes of this note, surge is defined as a rapid, very short term pressure variation caused by an accidental, unplanned event such as an emergency shutdown resulting from a power failure. Surge events are characterized by high pressure rise rates with no time spent at the peak pressure. The maximum duration of a surge event is about 5 minutes.
- Fatigue is associated with a large number of repetitive events. The key factors to consider are the size and frequency of the repeated event. For large pressure cycles, a lower number of events can be tolerated in the pipe lifetime. For smaller pressure changes, a greater number of events is acceptable.
- The gradual diurnal pressure changes which occur in most distribution pipelines as a result of demand variation will not cause fatigue. The only design consideration required for this type of pressure fluctuation is that the maximum pressure should not exceed the pressure rating of the pipe.

Fatigue

- Fatigue design Many materials will fail at a lower stress when subjected to cyclic or repetitive loads than when under static loads.
- This type of failure is known as fatigue.
- For thermoplastics pipe materials, fatigue is only relevant where a large number of stress cycles are anticipated.
- The important factors to consider are the magnitude of the stress fluctuation and the loading frequency.
- Where large stress fluctuations are predicted, fatigue design may be required where the total number of cycles in the operational lifetime of the pipe exceeds the material specific number. For smaller stress cycles, a larger number of cycles can be tolerated.

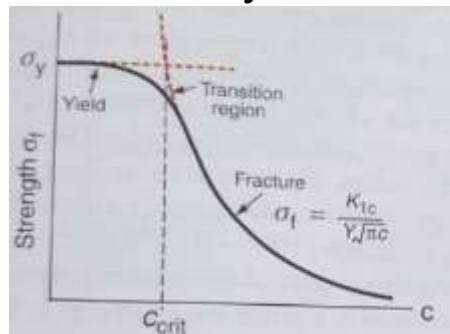

Designing against Crack Growth

Designing Against Crack Growth

- Crack growth condition: $K \geq K_c$

$$XY\sigma\sqrt{\pi a}$$

- Largest, most stressed cracks grow first!

- Result 1: Max flaw size dictates design stress.

Interior crack $X=1$

$$\sigma_{design} < \frac{K_c}{Y\sqrt{\pi a_{max}}}$$

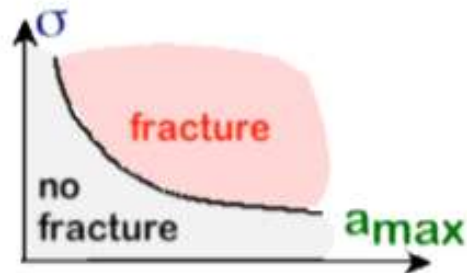

- Result 2: Design stress dictates max. flaw size.

$$a_{max} < \frac{1}{\pi} \left(\frac{K_c}{Y\sigma_{design}} \right)^2$$

NOTE:
only K_c/σ
is critical
for design!

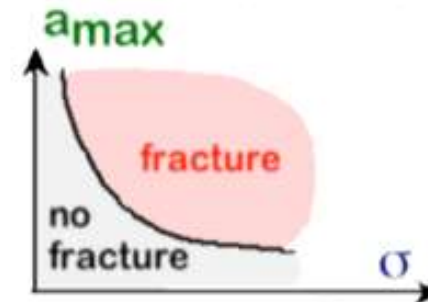

Fatigue load factors for PE pipes

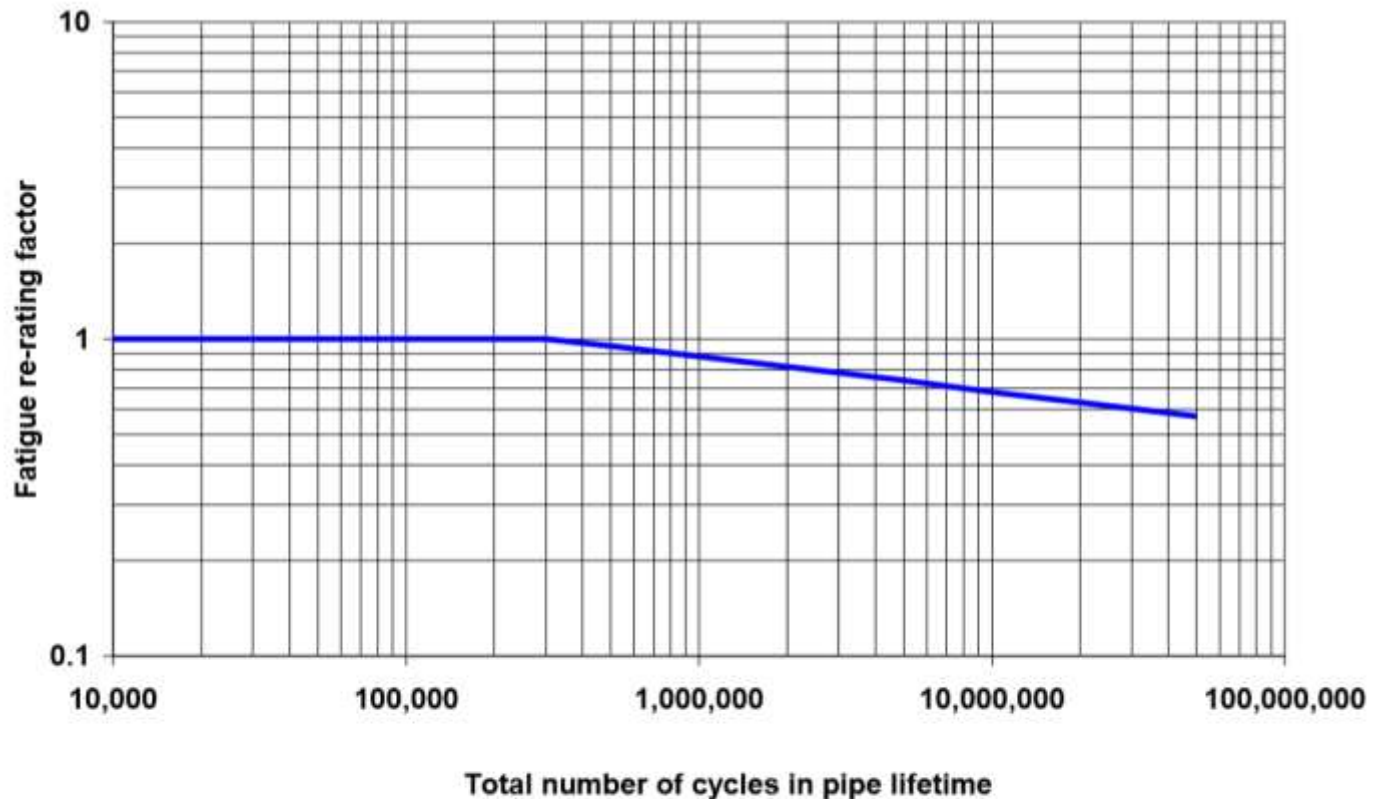

Figure 1: Fatigue load factors for polyethylene pipes

Recommended fatigue cycle factors for PVC-U, PVC-M and PVC-O

Using Table 1, the Maximum Cyclic Pressure Range for a given class of pipe can be calculated from the following formula:

$$\text{MCPR} = \frac{\text{PN}}{10} \times f$$

TABLE 1

Total Cycles	Approx. No. Cycles /day for 100y life	Fatigue Cycle Factors, f		
		PVC-U	PVC-M	PVC-O
26,400	1	1	1	1
100,000	3	1	0.67	0.75
200,000	5.5	0.81	0.54	0.66
500,000	14	0.62	0.41	0.56
1,000,000	27	0.50	0.33	0.49
2,500,000	82	0.38	0.25	0.41
5,000,000	137	0.38	0.25	0.41
10,000,000	274	0.38	0.25	0.41

UPVC Fatigue Applications

Selection of PVC-U pipe pressure class
fatigue applications

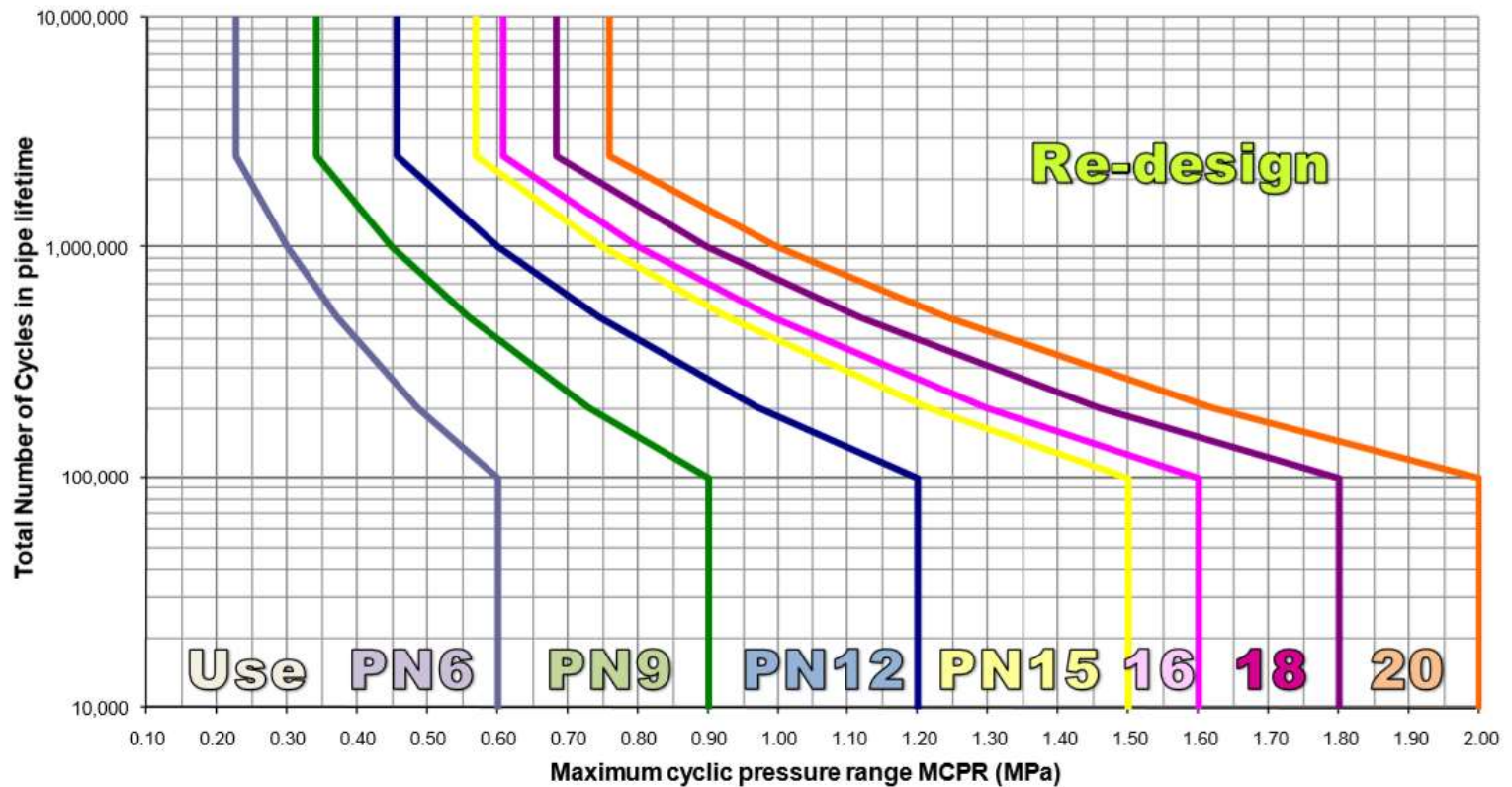

MPVC Fatigue Applications

Selection of PVC-M pipe pressure class
fatigue applications

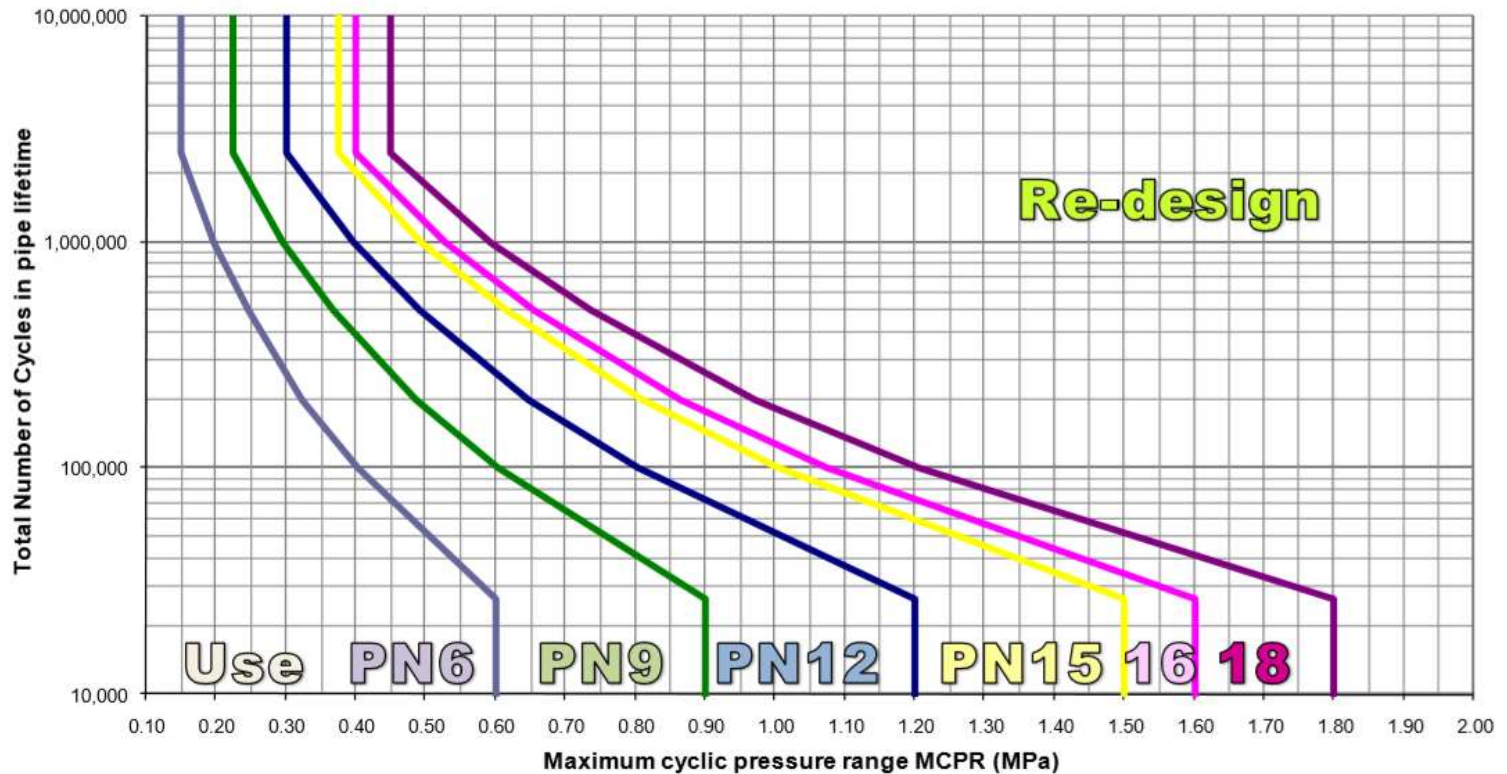

Mechanical requirements

Circumferential resistance

- Product standards shall state methods by which resistance to internal and external loadings is assured (Validated Design Parameters)

Longitudinal resistance

- For long rigid or semi-rigid pipes of small diameters, product standards shall state the resistance to bending moment or bending load for a specified span and loading condition.
- Alternatively, limiting values of length to diameter ratios shall be given in product standards. This is to help avoid problems when transporting, lifting, handling and installing pipes

Water Tightness

- All pipeline components, including joints, shall be designed, manufactured and tested to ensure water tightness throughout the design life under the relevant loading conditions indicated



Questions and Answers



SAPPMA Quality Workshop II Pressure fittings

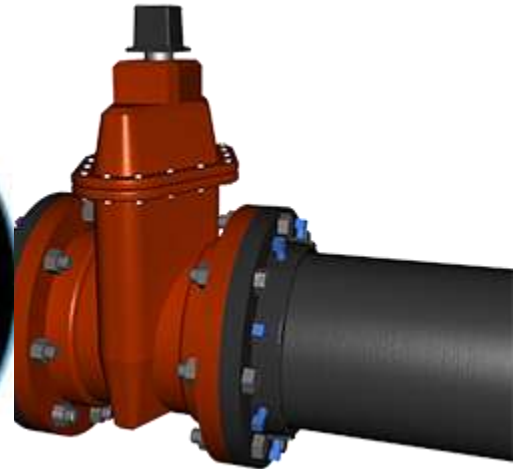
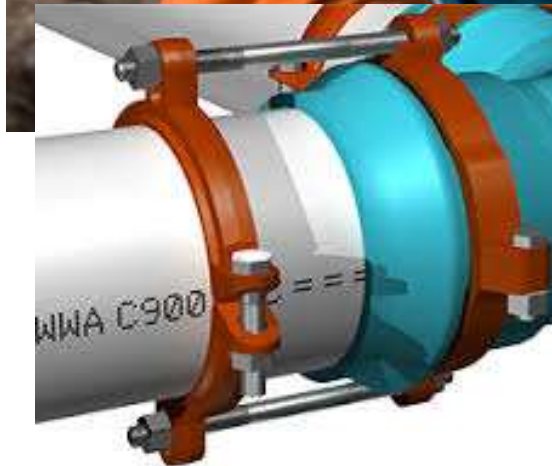

Co-presented by Justin Marsberg and Francois Prinsloo

Ian Venter

17-07-2019



Polymer and Plastics
Testing Laboratory



Pressure Pipe Systems; Fittings



Ian Venter
17-07-2019

Fitting Component

Fitting component, other than a pipe, which allows pipeline deviation, change of direction or bore. In addition, flanged socket pieces, flanged-spigot pieces and collars/couplings are defined as fittings

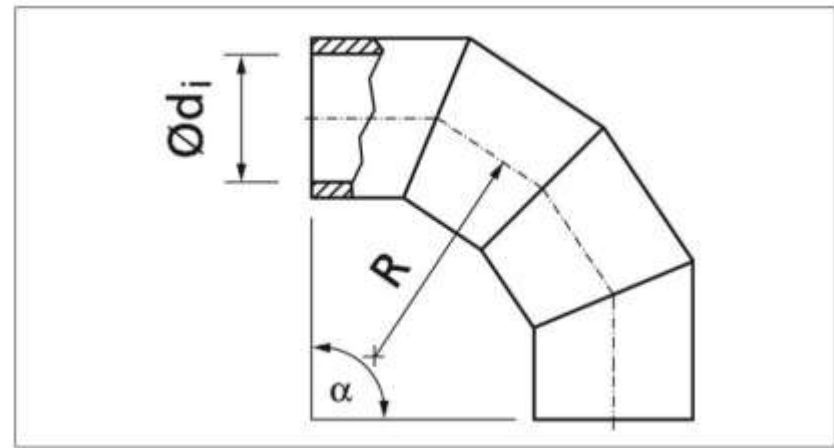

Pipe Joints

- Pipeline components shall be connected in such a way that the pipeline is watertight and withstands static and dynamic stresses. Joints and components shall conform to the relevant national standards, and international standards as is available, and be installed in accordance with the manufacturer's additional instructions.

Unrestrained Joints

- Pipelines with unrestrained joints shall be securely anchored at blank ends, tees, bends, tapers and valves to resist thrust arising from internal pressure.
- Anchors and thrust blocks shall be constructed to withstand the forces resulting from the internal pressure, including site test and dynamic forces, taking into account the safe bearing pressure of the actual surrounding soil. Concrete anchor blocks shall be of such a shape as to leave joints clear.

Restrained Joints

- Restrained joints shall be installed in accordance with the manufacturer's instructions.

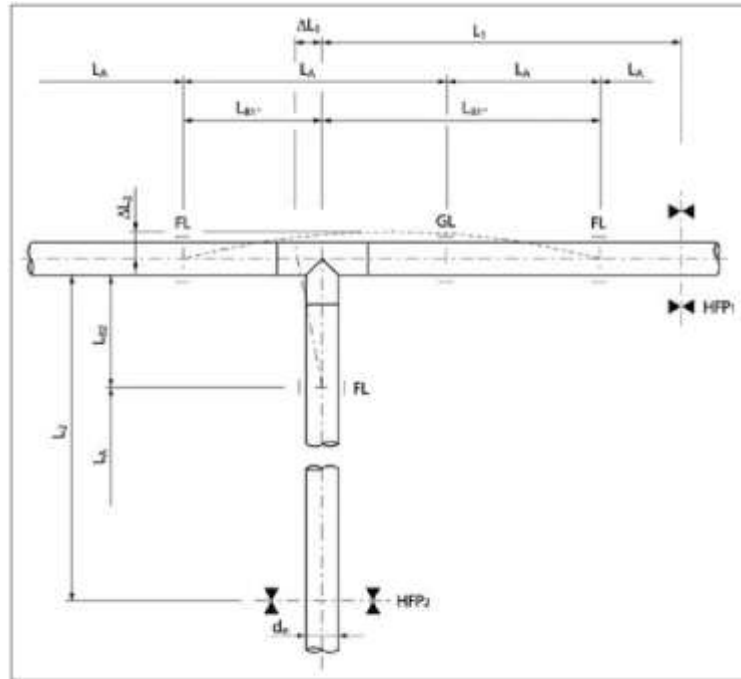

Figure 7.8 Pipe section for absorbing length changes

Welded joints

Welding shall be carried out only by personnel qualified according to national standards.

If such standards are not available, welding shall be performed by suitably trained personnel, using welding equipment and methods approved by the pipe and fitting manufacturer.



Lubricants and Adhesives for joints

- All lubricants and adhesives which can come into contact with potable water intended for human consumption shall comply with relevant national standards, transposing European Standards as available.



Joints

Product standards shall require that sealing materials comply with the requirements of the relevant national standards.

Joints having elastomeric seals shall be designed in such a way as to ensure water tightness throughout the design life, taking into account the long-term sealing material properties (e.g. elasticity, strength, relaxation, temperature sensitivity) and, where appropriate, the possibility of joint movements during the lifetime of the system.

If the joint includes parts having significant strength regression, product standards shall state the required performance and shall specify the necessary tests.

The product standards shall specify the types of joints by which the components are to be connected:

- rigid joints;
- adjustable joints;
- flexible joints.

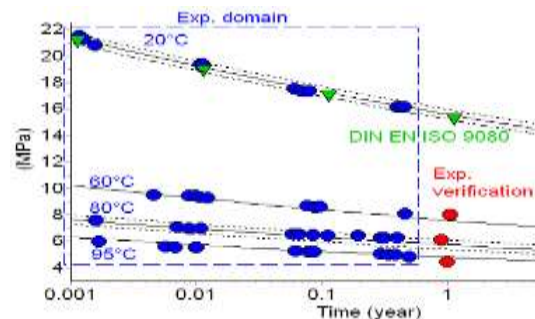

Joints continue

- The product standards shall also state if the specified joints are non-restrained or restrained:
- non restrained joints shall have adequate axial withdrawal to accommodate any axial spigot movement induced by temperature fluctuations and the Poisson contraction of the pipe under internal pressure in addition to the specified angular deflection;
- restrained joints shall be capable of withstanding the end-thrust due to internal pressure and, where applicable, due to temperature fluctuation and the Poisson contraction of the pipe under internal pressure.

Joints, Flexible and Rigid Joints

Joint; connection between the ends of two components including the means of sealing

Flexible Joint; Joint which permits significant angular deflection, both during and after installation and which can accept a slight offset of the center line

Rigid joint; Joint that does not permit significant angular deflection, either during or after installation



Pipe Materials Product Selector

Product Groups		Nominal Size Range (mm)	Double Iron	Cast Iron	Steel	Stainless Steel	PVC	HDPE	Polypropylene	MDPE/PEAD	HDPE/PE LDB	PPR	PE	Clay	Concrete	Alumina (Cement)	Copper	Lead
Dedicated																		
FlexLock (A, B)	Coupling	50 - 300	●		●													
	Flange Adapter	50 - 300	●		●													
QuickFit (A, C)	Coupling	40 - 300	●	●	●	●	●					●	●		●	●	●	
	Flange Adapter	40 - 300	●	●	●	●	●					●	●		●	●	●	
Large Diameter Unfitted (A, C)	Coupling	350 & greater	●	●	●	●	●					●	●		●	●	●	
	Flange Adapter	350 & greater	●	●	●	●	●					●	●		●	●	●	
	Step Coupling	350 & greater	●	●	●	●	●					●	●		●	●	●	
Dismantling Joints (A, B)		50 & greater	●	●	●	●	●		●	●	●	●	●		●	●	●	
Wall Couplings (A, B, C)		80 & greater	●	●	●	●	●		●	●	●	●	●		●	●	●	

Product Standards Joints

Rigid joints

- Product standards shall state the required performance of rigid joints and shall specify the necessary tests.

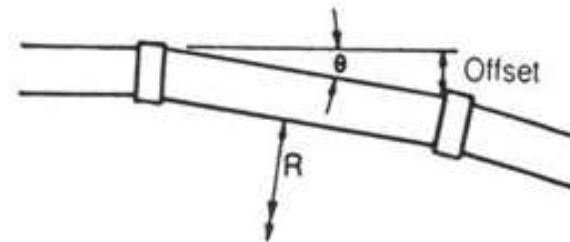

Adjustable joints

- Product standards shall state the required performance of adjustable joints and shall specify the necessary tests. The lowest value of the allowable angular deflection shall be validated to the standard

Angular deflection for adjustable Joints

Table 4 - Lowest allowable angular deflection of adjustable joints

DN	Radian	Degree
< 300	0,03	1°43'
$300 \leq DN \leq 600$	0,02	1°09'
$600 < DN \leq 1\ 000$	0,01	0°34'
$DN > 1\ 000$	$0,01 \times \frac{1\ 000}{DN}$	$0^\circ 34' \times \frac{1\ 000}{DN}$

Product standards shall state the values of allowable angular deflection or require the manufacturer to do so.

If adjustable joints include elastomeric gaskets they shall comply with the specific standard requirements as well as for their allowable angular deflection.

Flexible Joints

The lowest values for the allowable angular deflection of flexible joints shall be as shown.

DN	Class A		Class B	
	radian	degree	radian	degree
< 300	0,03	1°43'	0,06	3°26'
300 ≤ DN ≤ 600	0,02	1°09'	0,04	2°18'
600 < DN ≤ 1 000	0,01	0°34'	0,02	1°09'
DN > 1 000	$0,01 \times \frac{1\,000}{DN}$	$0^\circ 34' \times \frac{1\,000}{DN}$	$0,02 \times \frac{1\,000}{DN}$	$1^\circ 09' \times \frac{1\,000}{DN}$

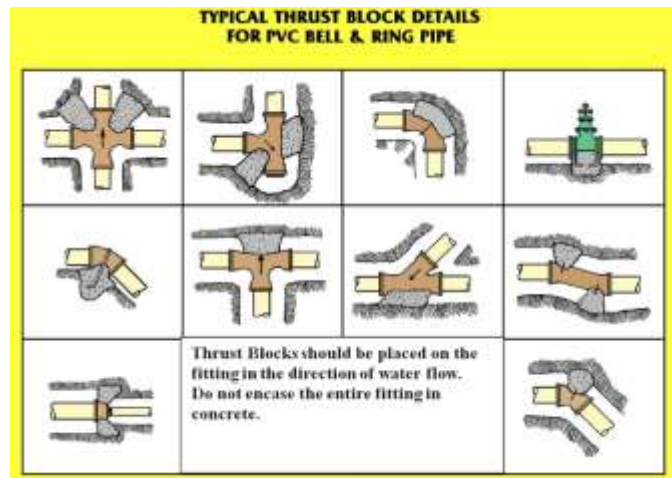

Plain ended pipe joint fitted with flexible coupling

- Where plain-ended pipes are jointed by couplings having a flexible joint at each end, the allowable angular deflection shall be attainable at each end of the coupling.

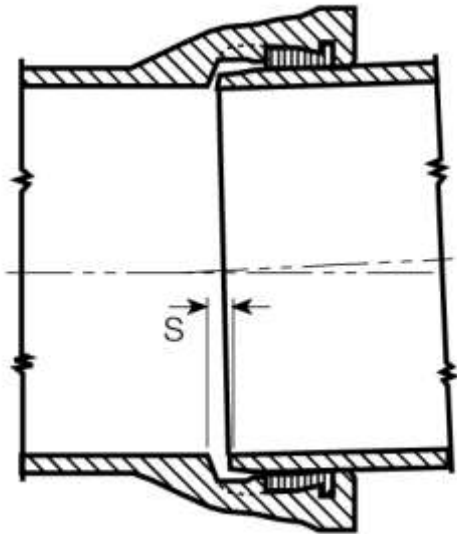

Validation of Joints

- The water tightness of flexible joints to internal and external pressure shall be demonstrated under the following conditions:
- Condition 1: joint deflected to the allowable angular deflection and, where applicable, to its thermal and Poisson's axial withdrawal allowance.
- Condition 2: joint subjected to a transverse shear across the joint and, where applicable, to its thermal and Poisson's axial withdrawal allowance.
- The product standard shall state whether conditions 1 and 2 are tested separately or in combination.
- The product standard shall state the value of the transverse shear across the joint to either a minimum of 10 DN expressed in newtons (test in combination) or 20 DN expressed in newtons (separate tests), but, where applicable, the diametric deflection of the spigot shall not exceed the maximum allowable pipe deflection.
- The tests shall be carried out as type tests. The product standard shall state the diameter to be tested in order to cover the whole range of diameters.

Type Testing of Joints

- Type testing shall take into account all relevant unfavorable manufacturing tolerances (e.g. maximum and minimum diameters of socket and spigot, ovality, lip length).
- The test pressures shall be at least:
- PEA (allowable site test pressure) for all kinds of joints;
- 80 kPa below atmospheric for joints whose tightness or gasket stability is influenced by the pressure.

Type Testing of Joints Continue

- A cyclic pressure type test shall be carried out under condition 2 or under a combination of conditions 1 and 2 as stated in the product standard. The test pressure shall vary between PMA (allowable maximum operating pressure) and 0,5 PMA or PMA - 500 kPa, whichever is the greater. The test shall comprise at least 24 000 cycles.
- Satisfactory service experience of at least 10 years prior to the first date of publication of this standard for a particular joint product combination for water supply shall be accepted as satisfying this cyclic type test requirement. This 10 years allowance is valid only for joints the design of which has not been changed within this period of time.
- Restrained joints shall be tested while subjected to the whole end thrust defined in the standard
- Product standards shall state any additional performance requirements of flexible joints and shall specify the necessary tests.

Tests for joints

The tests shall be carried out on two pipes or sections of pipe, jointed and supported in such a way that, where appropriate, they can move in relation to each other to limits of the requirements stated in product standards.

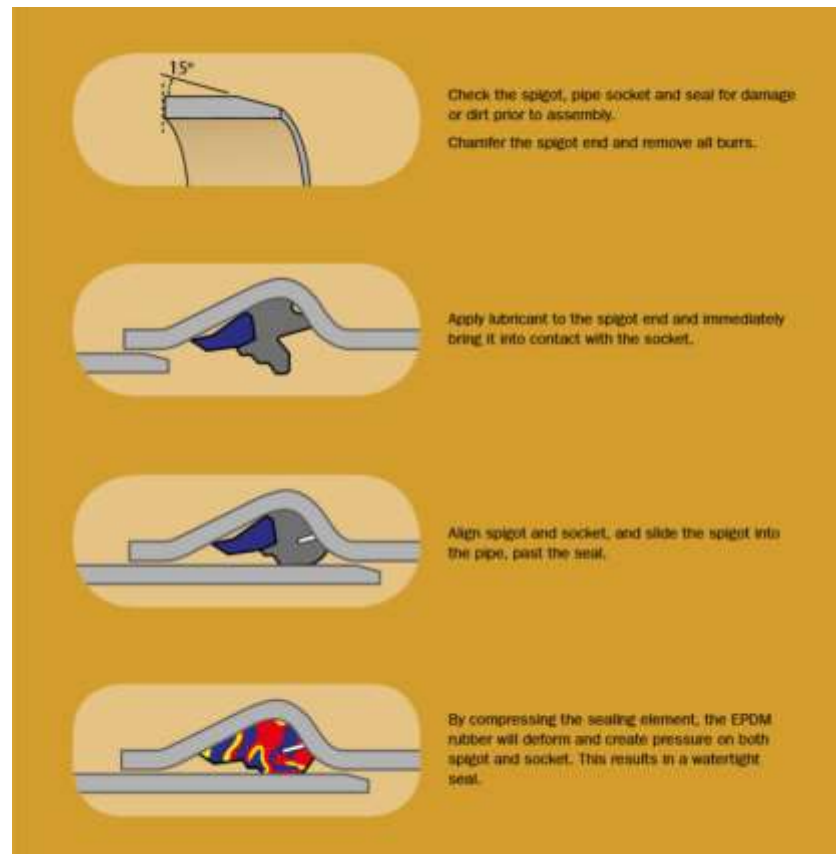

Connection to structures

- Connections to structures (shafts, buildings, etc.) shall be made in such a way as to avoid undue stresses being exerted either on the pipes or the structures.
- Measures suitable for this purpose include, for example, articulated pipe joints or flexibly mounted wall bushes.
- Where pipes enter or pass through structures such as anchor blocks or valve chambers or have a concrete surround consideration shall be given to the need to provide flexibility to the pipeline on either side of the structure.
- The need shall be met by introducing two flexible joints to the pipeline on each side of the structure or by any other system specified by the designer.
- Care shall also be taken to ensure thorough compaction of the bedding material beneath the pipe immediately adjacent to the structure, particularly where over-excavation of the trench has occurred.
- In some circumstances, consideration shall be given to backfilling this over excavation with lean mix concrete (i.e. with low cement content) to the underside of the pipe bedding material.

Fittings and Pipes are not the whole system

Components

Accessories components, other than pipes, fittings or valves, which are used in a pipeline, e.g. glands, bolts, locking rings for joints, ferrules

adjustable joint

Joint which permits significant angular deflection at the time of installation but not thereafter

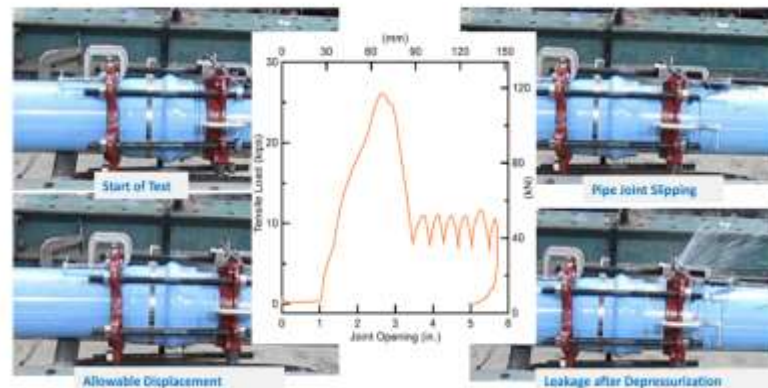

Hydraulic roughness of fittings

Hydraulic roughness value

The hydraulic roughness value k to be considered in the calculation shall be either:

design roughness value k_1 , including influences of pipes and joints; or
design roughness value k_2 including influences of pipes, joints, fittings and valves, If k_1 is used, secondary head losses shall be considered

Possible long term increases of roughness shall be considered in establishing the design roughness value.

Other components, such as meters, pumps etc., shall be considered separately as specific head losses

Head Losses in Fittings

Hydraulic roughness value Head losses which occur at fittings and valves can generally be taken into account in two ways:

the first method uses experimental results which demonstrate that head losses are approximately proportional to the square of flow velocity; coefficients are available for various types of fittings;

the second method makes use of an “equivalent length” of straight pipe to give the same loss of head as the fittings.

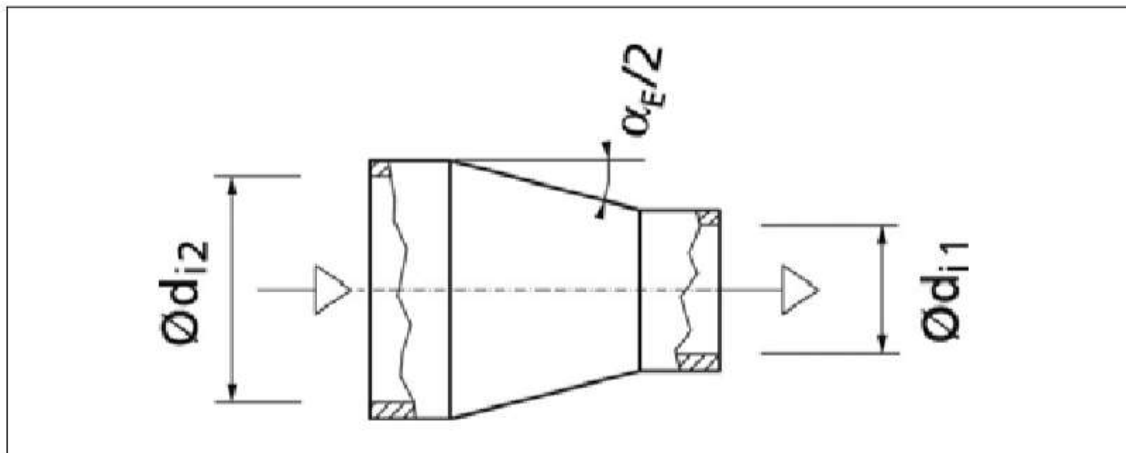
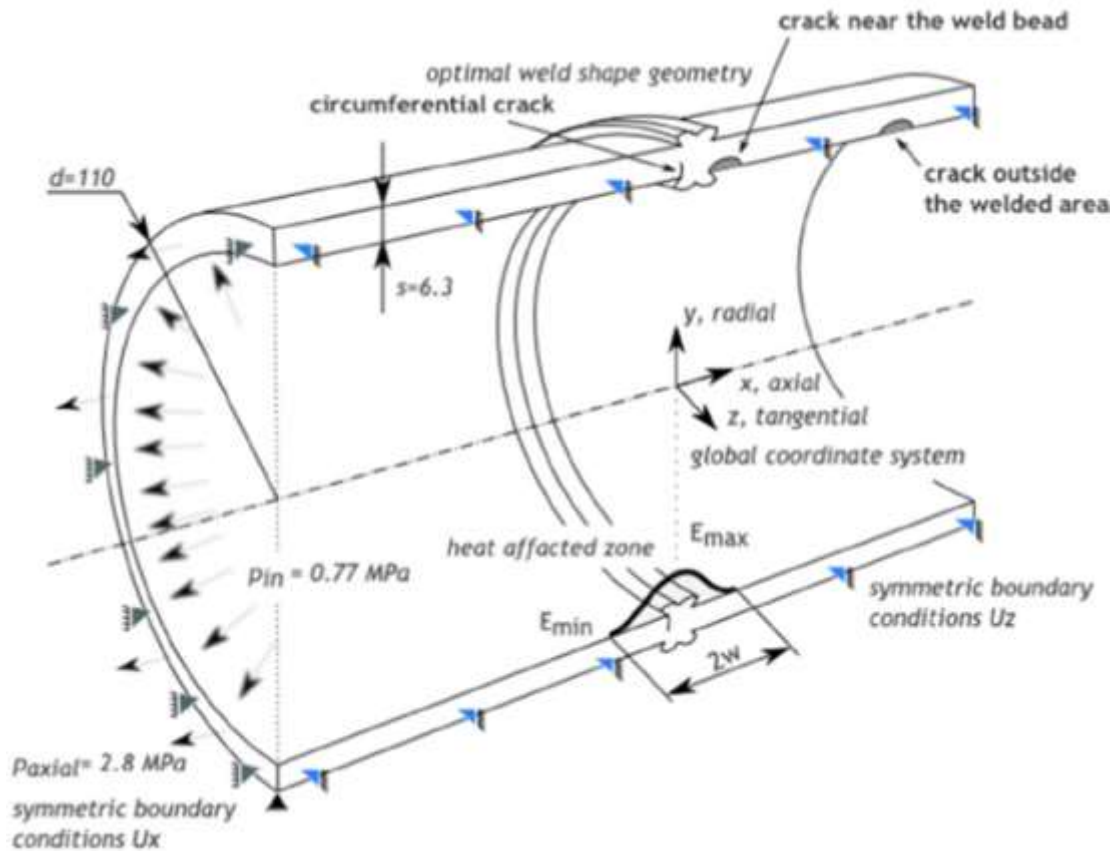

Figure 7.6 Conical enlargement of the flow cross section

Testing of fittings and Accessories

Tests for fittings, accessories, valves and other components
Test methods shall be stated in product standards to demonstrate suitability for use.



Installation of valves, fittings and other components

Installation work shall not cause unacceptable stresses to the system.

Measures shall be taken to accommodate predicted internal and external forces.

Where necessary, unbalanced forces shall be resisted by suitable structures.

Any special requirements specified by the designer shall be complied with.

Where components made from a particular material require partial or full concrete encasement, this shall be stated in the product standard.

The dimensions and details of the concrete encasement shall be such that it is capable of withstanding any intended loads applied to the pipe. This may require the use of reinforced concrete. Provision shall also be made to resist thrust.

Water Test

General requirements

Every pipeline which has been constructed shall undergo a water pressure test to ensure the integrity of pipes, joints, fittings and other components such as anchor blocks.



Important step in Water Testing

At all stages of testing, the planned sequence and any variation of operations shall be controlled to avoid danger to personnel.

All personnel shall be clearly informed of the intensity of the loading on temporary fittings and supports and the consequences if failure occurs.



Backfilling and Anchorage

Prior to the pressure test, the pipes shall, where appropriate, be covered with backfill material such that changes in ground condition, which may lead to leaks, are avoided.

Backfilling over joints is optional. Permanent abutments or anchorages shall be constructed to withstand thrust at the test pressure.

Concrete anchor blocks shall be allowed to develop adequate strength before testing begins.

Care shall be taken to ensure that caps or other temporary blanking fittings are adequately anchored, with the load distributed according to the strength of the supporting ground.

Any temporary supports or anchorage at the ends of the test section shall not be removed until the pipeline is depressurized.

Main Water Test Phase

The viscoelastic creep due to the stress caused by STP is interrupted by the integrated pressure drop test.

The rapid decrease of the pressure leads to a contraction of the pipeline.

Observe and record for a period of 30 min (main test phase) the increase of pressure resulting from the contraction. The main test phase is considered to be successful if the pressure curve shows an increasing tendency and does not decrease at any time of this 30 min period, which is normally long enough to get a good indication.

If during that period the pressure curve shows a falling tendency, it indicates a leak within the system.

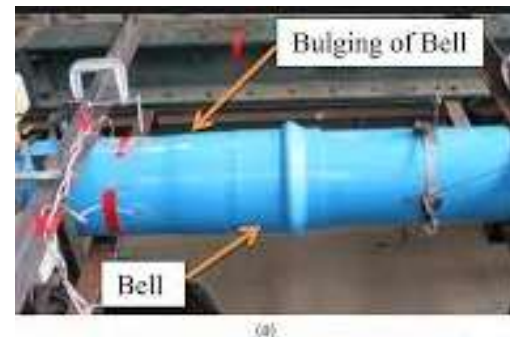
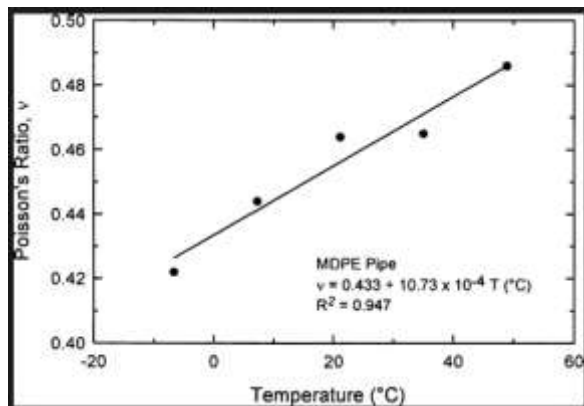

Main Water Test Phase (Continue)

In case of doubt extend the main test phase to 90 min.

In that case the pressure loss is limited to 25 kPa from the maximum value occurring within the contraction phase.

If the pressure drops by more than 25 kPa the test fails.

It is advisable to check all mechanical fittings before visually inspecting the welded joints.

Rectify any defect in the installation revealed by the test and repeat the test.

The repetition of the main test phase may only be done by carrying out the whole test procedure including the relaxation period of 60 min in the preliminary phase.

Unbalanced Thrust

Forces are exerted at valves, changes in direction and diameter, branches and blank ends.

These forces shall be compensated by an adequate number of restrained joints, thrust blocks or other anchorages.

Where thrust blocks are to bear against the soil the safe bearing pressure shall be determined.

The possibility of shear failure, sliding and potential disturbance of the thrust block by subsequent excavation shall be considered.

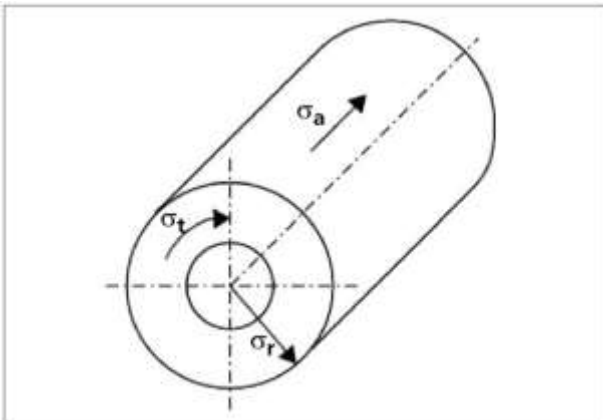

Figure 7.11 Radial (σ_r), Axial (σ_a) or Tangential (σ_t) stress

Protection against aggressive environment

The designer shall assess potential damage due to contact with soils and various pollutants

The designer shall consider, with reference to product standards, appropriate measures to protect pipelines against undesired effects due to aggressive environments and the conveyed water.

The designer shall specify the method for the repair of coatings, linings and for any additional protection of joints.



Protection against corrosion and contamination

External protection

- Repairs and additions to the pipe coatings at faults and at pipe joints shall be effected as specified by the designer in accordance with the product standard, taking into account the manufacturer's instructions.
- The materials and method to be employed shall depend on the material originally used and the protection required, e.g. plastics sleeving, bitumen sheathing, protective tape, anticorrosive blankets, shrink-on hoses or shrink-on formed parts.
- Any exposed pipeline components after being cleansed, de-rusted and dried, shall be protected e.g. by strips, bitumen strips, by pouring round anticorrosive media or by tapes or shrink-on formed parts.
- Where pipes have plastics coatings or loose plastics sleeving, care shall be taken to prevent contact with large sharp-edged stones, shale, flints or any harmful substance. Unacceptable heat effects, such as from district heating pipelines, shall be avoided.

Protection against corrosion and contamination

Continue

- Inspection and testing of anticorrosive external coatings
Where the designer specifies testing or when laying pipeline components made of metallic materials with an electrically non-conducting coating to the pipes and a cathodic protection of the system, the coatings shall be tested with an electrical testing apparatus and, if necessary, properly repaired.
- After visual inspection, the continuity and resistance of coatings of cathodic protected pipeline systems shall be tested with an electrical spark test device or equivalent before backfilling.
- The test voltage shall be specified by the designer depending on the type and the thickness of the coating material.
- Any defects disclosed shall be rectified by a procedure compatible with the original coating and the repaired area retested.

Protection against corrosion and contamination Continue

Internal protection

- Any damage to the internal coating or lining shall be repaired in accordance with the manufacturer's instructions. Where specified by the designer, the internal coating or lining of the joint area shall be effected in accordance with the design specification. Internal coating or lining shall comply with the relevant national standards, transposing European Standards as available, for materials in contact with potable water

Protection against corrosion and contamination Continue

- Ground contamination by organic substances, such as hydrocarbons and chlorinated hydrocarbons, may have adverse effects upon:
 - the quality of potable water (by permeation of organic substances through the pipeline walls);
 - the properties of some plastics components;
 - the permeability and durability of some elastomeric gaskets;
 - the corrosion resistance of some metallic components.
- Where a soil survey indicates such ground contamination, measures such as the following should be taken into consideration by the designer:
 - change to less vulnerable materials in the affected zones;
 - lay pipes subject to permeation in protection ducts;
 - use suitable elastomer for joints;
 - use suitable corrosion protection for metallic materials;
 - exchange the soil;
 - re-route the pipeline.

Questions and Answers



SAPPMA Quality Workshop II Pressure Systems

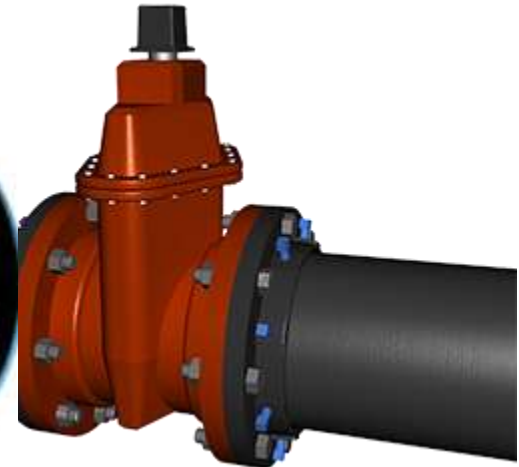
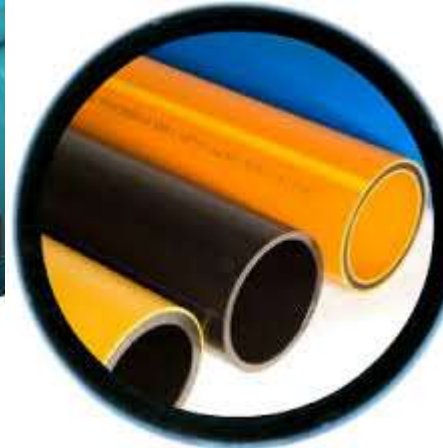

Co-presented by Justin Marsberg and Francois Prinsloo

Ian Venter

17-07-2019



Polymer and Plastics
Testing Laboratory



Pressure Pipe Systems; System



Ian Venter
17-07-2019

SAPPMA's Purpose

ISBN 978-0-626-20750-2

SANS 4427-5:2008

Edition 1

ISO 4427-5:2007

Edition 1

**INTERNATIONAL
STANDARD**

**ISO
1452-5**

First edition
2009-12-01

SOUTH AFRICAN NATIONAL STANDARD

**Plastics piping systems — Polyethylene (PE)
pipes and fittings for water supply**

Part 5: Fitness for purpose of the system

**Plastics piping systems for water supply
and for buried and above-ground
drainage and sewerage under pressure —
Unplasticized poly(vinyl chloride)
(PVC-U) —**

**Part 5:
Fitness for purpose of the system**

System Standard SANS ISO 4427

Introduction

ISO 4427, the system standard, specifies the requirements for a piping system and its components when made from polyethylene (PE). The piping system is intended to be used for water supply intended for human consumption, including the conveyance of raw water prior to treatment and that of water for general purposes.

System Standard ISO 1452

Introduction

The System Standard ISO 1452, of which this is Part 5, specifies the requirements for a piping system and its components made from unplasticized poly(vinyl chloride) (PVC-U). The piping system is intended to be used for water supply and for buried and above-ground drainage and sewerage under pressure.

Part 3 and 5 Certification



Certificate / Zertifikat

20160504

Hereby it is certified that / Hiermit wird bescheinigt, dass die

is producing Pipe fittings made of PE due to / Formstücke aus PE fertigt gem. der

DIN EN 1555-3 (2013-01)

and / und

DIN EN 12201-3 (2013-01)

The used moulding material meets the requirements given in EN 1555-1 and EN 12201-1 and the fitness for purpose was proofed by testing due to EN 1555-5 and EN 12201-5. /

Die hierfür verwendeten Formmassen entsprechen der DIN EN 1555-1 und DIN EN 12201-1 und die Gebrauchstauglichkeit wurde durch Prüfungen gem. DIN EN 1555-5 und DIN EN 12201-5 nachgewiesen.

Garbsen, 2016-12-13

A handwritten signature in blue ink, appearing to read 'Andreas Kinzel'.

Dr.-Ing. Andreas Kinzel

- Managing Director / Geschäftsführer -

Part 3 and 5 Certification

Austrian Standards plus GmbH issues this certificate.

Holder of certificate:

Factory:

Product:

fusion fittings for polyethylene-piping systems for water supply

Electrofusion socket Fittings (connection type A), made of PE 100, also suitable for potable water (TW), SDR 7,4 / SDR 11 / SDR 17 / SDR 17,6, E-coupler dn (mm): 20 to 500, E-coupler (SDR 17) dn (mm): 90 to 500, E - Tee dn (mm): 20 to 225, E - elbow 90° dn (mm): 20 to 225, E - bend 45° dn (mm): 20 to 225, E - Reducer dn (mm): 25/20 to 225/160, E - End cap dn (mm): 20 to 225

Standard:

ÖNORM EN 12201-3

This certificate attests the conformity of the product listed above with the requirements of the standard referenced.

Conformity mark:

The holder of this certificate is entitled to mark the product with the phrase "ÖNORM geprüft" in conjunction with a reference to the standard as well as with the conformity mark:



Fitness for purpose of the system SANS ISO 4427-5

1 Scope

This part of ISO 4427 specifies the characteristics of the fitness for purpose of assembled piping systems made from polyethylene (PE) intended for the conveyance of water for human consumption, including raw water prior to treatment and water for general purposes.

It also specifies the test parameters for the test methods to which it refers. In conjunction with the other parts of ISO 4427, it is applicable to PE pipes, fittings, valves, their joints and to joints with components of other materials, intended to be used under the following conditions:

- a) a maximum operating pressure (MOP) up to and including 25 bar¹);
- b) an operating temperature of 20 °C as the reference temperature.



Fitness for purpose of the system SANS ISO 4427-5

Continue

- NOTE 1 For applications operating at constant temperatures greater than 20 °C and up to 40 °C, see ISO 4427-1:2007, Annex A (Temperature derating).
- NOTE 2 ISO 4427 covers a range of maximum operating pressures and gives requirements concerning colors and additives.
- It is the responsibility of the purchaser or specifier to make the appropriate selections from these aspects, taking into account their particular requirements and any relevant national guidance or regulations and installation practices or codes.



Content SANS ISO 4427-5

1 Scope

2 Normative references

3 Terms, definitions, symbols and abbreviated terms

3.1 electrofusion joint

3.2 butt fusion joint

3.3 saddle fusion joint

3.4 mechanical joint

3.5 fusion compatibility



Content SANS ISO 4427-5

4 Fitness for purpose of the system

4.1 General

4.2 Preparation of assemblies for testing

4.2.1 General

4.2.2 Grouping

4.2.3 Fitting types



4.3 Electrofusion joints

4.3.1 Assemblies with pipes and components having different MRS and SDR

a) Preparation

b) Test pieces

c) Requirement

4.3.2 Assemblies under extreme conditions

a) Preparation

b) Test pieces

c) Requirement



Content SANS ISO 4427-5

4.4 Butt fusion joints

4.4.1 Assemblies between components of different MRS

The following is to be carried out if requested by the purchaser or end user

- a) Preparation
- b) Test piece
- c) Requirement

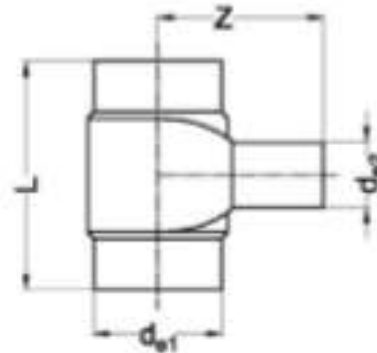

Content SANS ISO 4427-5

4.4.2 Assemblies under extreme conditions

The following is to be carried out if requested by the purchaser or end user.

a) Preparation

b) Test piece

c) Requirements

4.5 Mechanical jointing

a) Preparation

b) Test piece

c) Requirements

4.6 Conditioning

4.7 Retest in case of failure at 80 °C

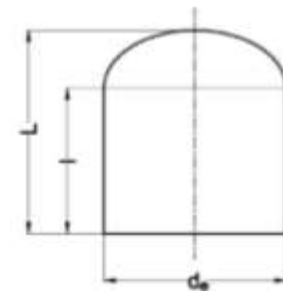

Fitness for purpose of the system

ISO 1452

1 Scope

This part of ISO 1452 specifies the characteristics for the fitness for purpose of unplasticized poly(vinyl chloride) (PVC-U) piping systems intended for water supply and for buried and above-ground drainage and sewerage under pressure.

It also specifies the test parameters for the test methods referred to in this part of ISO 1452.

In conjunction with ISO 1452-1, ISO 1452-2, ISO 1452-3 and ISO 1452-4, it is applicable to joints and assemblies with components of PVC-U, other plastics and non-plastics materials intended to be used for the following:

- a) water mains and services buried in ground;
- b) conveyance of water above ground for both outside and inside buildings;
- c) buried and above-ground drainage and sewerage under pressure;



Fitness for purpose of the system ISO 1452 Continue

- It is applicable to piping systems intended for the supply of water under pressure up to and including 25 °C (cold water) intended for human consumption and for general purposes as well as for waste water under pressure.
- This part of ISO 1452 is also applicable to components for the conveyance of water and waste water up to and including 45 °C. For temperatures between 25 °C and 45 °C, Figure A.1 of ISO 1452-2:2009 (Temperature derating) applies.
- NOTE The producer and the end-user can come to agreement on the possibilities of use for temperatures above 45 °C on a case-by-case basis.

Content to ISO 1452

- 1 Scope
- 2 Normative references
- 3 Terms and definitions, symbols and abbreviations
- 4.1 Assemblies with non-end-load-bearing joints
- 4.2 Assemblies with end-load-bearing joints
- 4.3 Short-term pressure test for leaktightness of assemblies
- 4.4 Short-term negative pressure test for leaktightness of assemblies
- 4.5 Long-term pressure test for leaktightness of assemblies

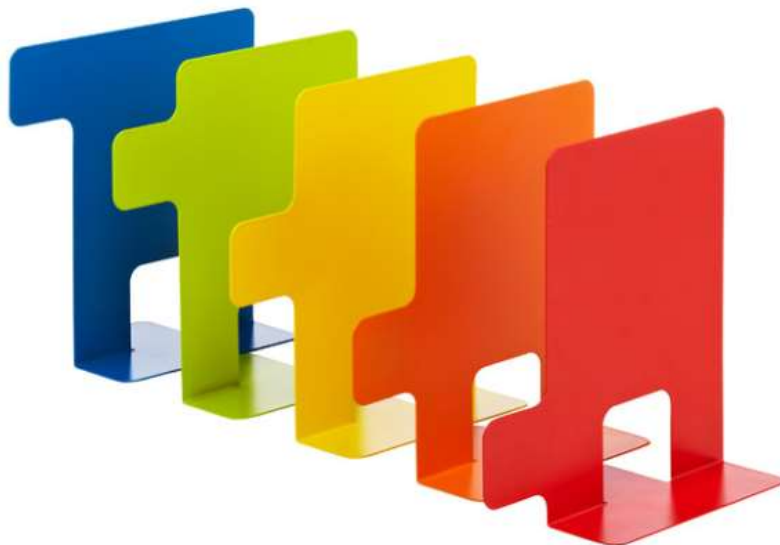

Questions and Answers



SAPPMA Quality Workshop II

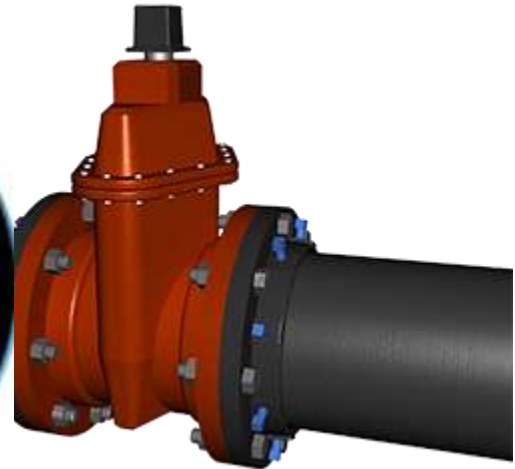

Co-presented by Justin Marsberg and Francois Prinsloo

Ian Venter

17-07-2019



Polymer and Plastics
Testing Laboratory



Pressure Pipe Systems; Conformance



Ian Venter
17-07-2019

Conformancy and Life Expectancy



*Plastics Industry Pipe Association
of Australia Limited* ACN 088 511 686

Life Expectancy for Plastics Pipes

INTRODUCTION

Based on the use of 50-year stress regression data, it has been incorrectly assumed that plastics pipe systems have a life expectancy of 50 years. In reality, such systems can reasonably be expected to last 100 years or more.

PE and PVC pipes and fittings were introduced into Australia during the 1950's, mainly for water supply and irrigation, but also for fuel gas and industrial applications

Your Design factor determines your design stress and not design Life

The creep rupture characteristics of these materials necessitated a new method for selection of design stress, compared with other materials in use at the time, etc.

The method adopted was that already in use in Europe - using the creep rupture (stress regression) curve, select a time and establish the associated burst stress. **Apply a design factor to the burst stress to give the design stress.**

The time chosen was 50 years, already adopted in Europe, and is still in use today in ISO, and CEN Standards. The use of this particular time interval has led to the misunderstanding that it represents the pipe life.



Misunderstanding Design Specification

Similarly, the use of 50-year modulus values for use in ring deflection calculations for non-pressure pipes has also led to misunderstanding regarding life.

The following extract from, Polyethylene Pipeline Code, explains why prediction of system life should not be based on the arbitrarily chosen time value.

TEAM MEMBERS



Role & Responsibilities

SAPPMA
australian special pipe & pipe manufacturers association

Prediction on system Life

Pressure pipe systems

Selection of allowable stress is based on long term pressure testing in the laboratory and regression analysis applied to the data obtained.

The 50-year point is arbitrarily chosen for this basis, as for all thermoplastic pipes. A factor is applied to the 50-year point in order to provide the design stress.

It shall not be taken that either: (a) the pipes weaken with time; or (b) the predicted life is 50-years.

System life is dependent on many factors. If the design stress were used in relation to the regression curve, predicted pipe life would be indefinite, not 50-years.



Elements for Managing System/Product Performance

As with other materials, the life is ***dependent on manufacture, transport, handling, installation, operation, protection from third party damage and other external factors.***

Provided that pipeline system components are ***appraised and supplied to nominated industry standards under third-party product certification systems, and provided pipelines are designed and constructed correctly, then the likelihood of failure is minimized.***



How long will it last?

For correctly manufactured and installed systems, the actual life cannot be predicted, but can logically be expected to be well in excess of 100 years before major rehabilitation is required.

If a system life is to be assigned beyond 100 years, it has to be based on the likelihood of failure arising from the above factors, not the pipe regression curve. Pipe strength has been shown not to decrease with time-in fact, it increases slightly. "Instantaneous " burst pressure after a period in service will be at least equal to that of new pipe.

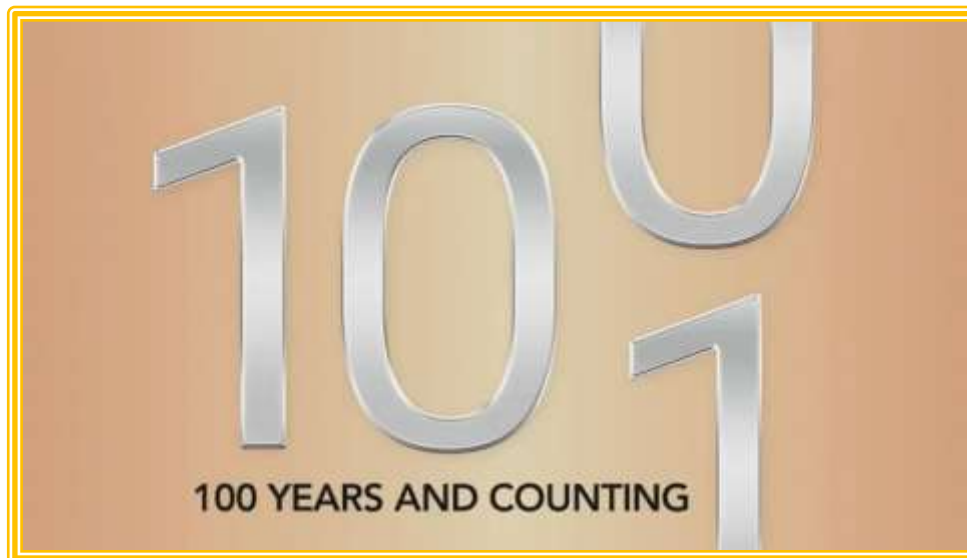

Your Role in Conformance



Procurement Process

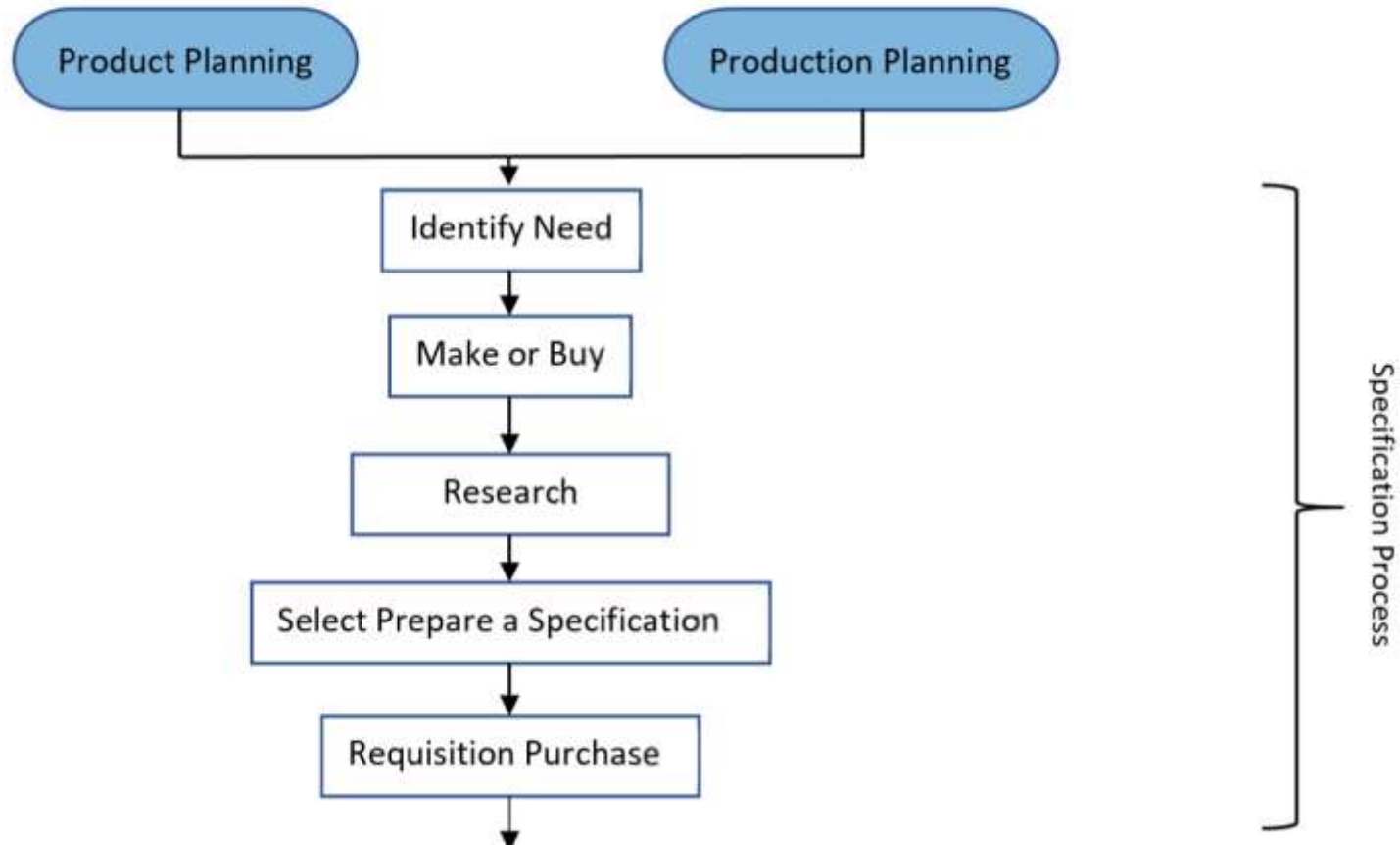

Your Role does not stop after Specification

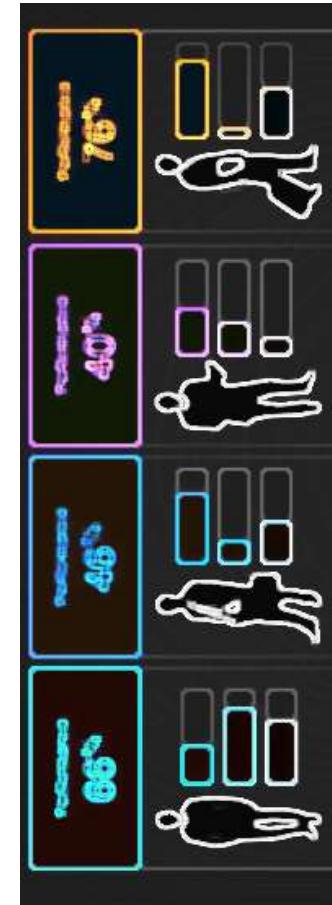
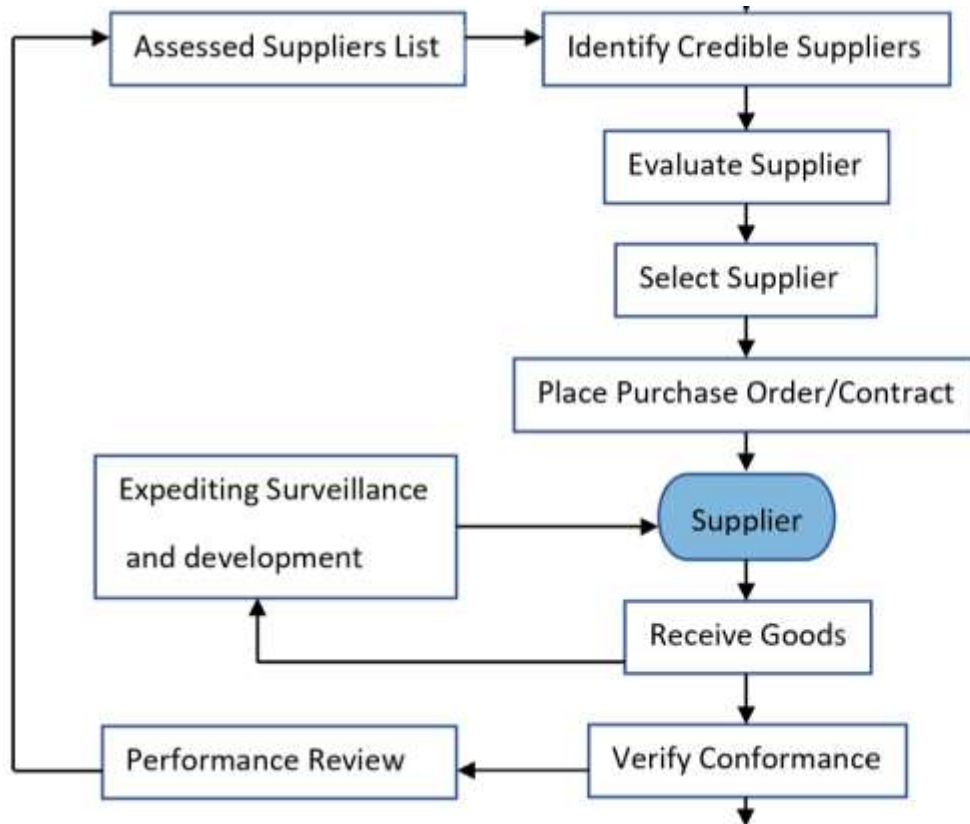

Evaluation Process

Surveillance Process

Acceptance Process must be driven by the Specification

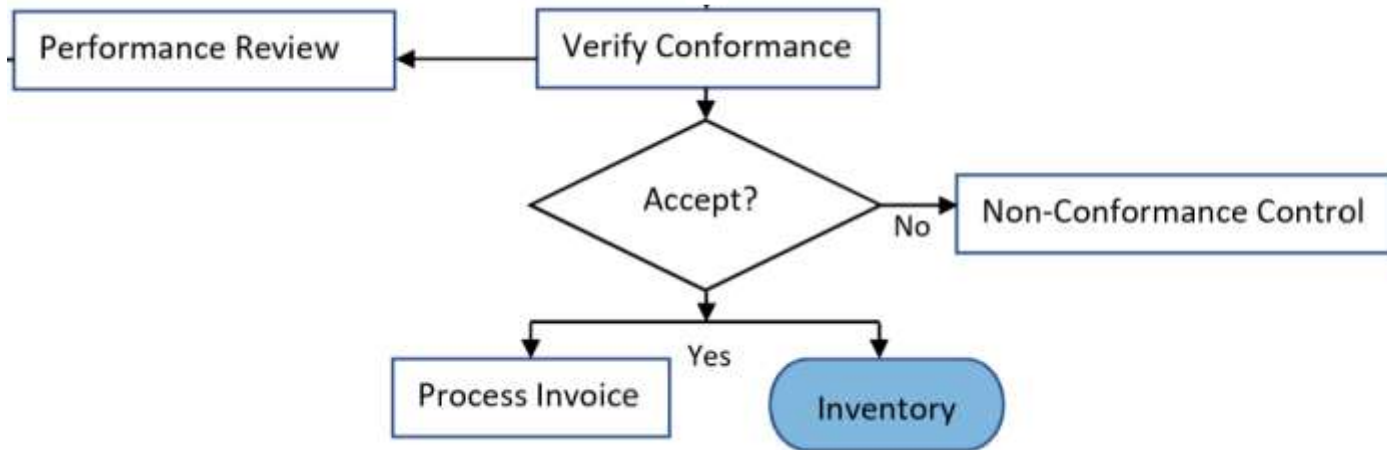

Acceptance Process



How do we turn it into sustainable quality management?

What exactly is sustainable quality management?

Traditional definition

A system, enterprise or function that can be sustained or maintained over a relatively long period of time.



What exactly is sustainable quality management?

The term management refers to:

All the activities that are used to coordinate, direct, and control an organisation. In this context, the term management does not refer to people. It refers to activities.

ISO 9001 uses the term top management to refer to people.

A management system refers to:

A set of interrelated or interacting processes that organisations use to implement policy and achieve objectives.

One definition of sustainable quality management systems:

Those systems that cover the whole life of the product and which do so in a manner that enables them to be successfully implemented in the long term

The manufacturing process overview for a utilities project

**Raw Material
Manufacturer**

**Pipe and Fitting
Manufacturer**

**Contractor or
Utility**

Input

Output

Input

Output

Process Customer

Petro-
chemical
substances &
additives
complying
with
standards
/requirements

PE100/PVC/
Additives
compounds
of defined
composition
and
formulation
complying
with
standards

PE 100/PVC/
Additives
compounds
complying
with
standards

Pipes and
fittings
complying
with
standards

Pipes and
fittings
complying
with
standards
and
specifications

The installation and operation process overview for a utilities project

Contractor or Utility

Utility Operations Branch

Utility Customer

Input

Output

Input

Output

Process Customer

Pipes and fittings, concrete, bedding material etc. complying with standards and specifications

Pipeline installed and commissioned in accordance with standards and specifications

Take over pipeline meeting operational requirements

Operate and maintain pipeline in accordance with internal procedures

Receive a supply or water or gas meeting regulatory standards and expectations

A series of strong Quality Management Systems provide the links

Does your pipe producer have ISO 9001 certification? If so they should have quality management systems (QMS) which should be implemented at each stage of the manufacturing, installation and operation process.

There should be continuity between the different QMS, which, where possible, should refer to common standards.

The QMS requirements and associated specifications etc. should be tied in to international standards (ISO) whenever possible.



Raw material manufacturer key QMS



QMS according to ISO 9001

Compliance with international regulations eg. ISO/SANS/Company procedures

In compliance with any national regulations eg. SANS/SABS/SATAS Permit conditions

Regularly audit suppliers

QMS according to ISO 9001

Comprehensive AoC system eg. SATAS

Having 3rd party certification for the compounds – PE100+/PVC formulations

In compliance with any national regulations

PVT –Process Verification tests

QMS according to ISO 9001

Fully documented shipments inc. 3rd party

Pipe and fitting manufacturer key QMS

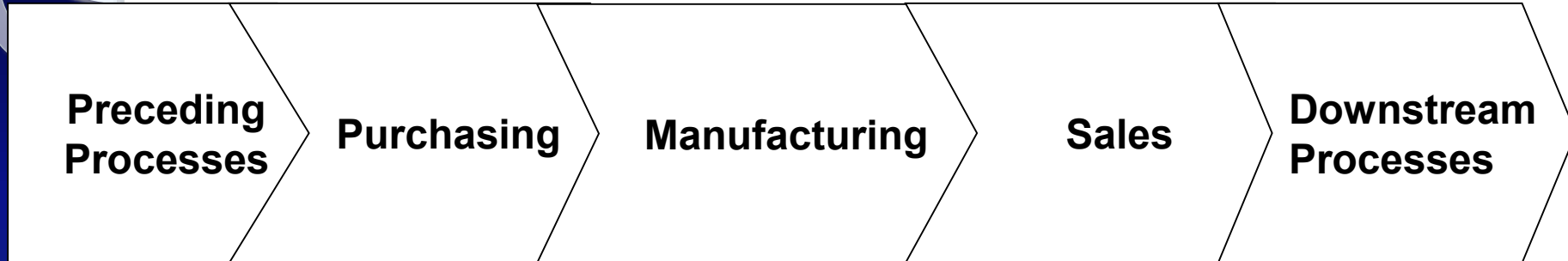

QMS according to ISO 9001

Consider 3rd party approved lists e.g. PE100+

Fully documented shipments inc. 3rd party certificates

Regularly audit raw material manufacturer

QMS according to ISO 9001

Comprehensive AoC system e.g. SATAS

Having 3rd party certification eg. Quality Marks

Use traceability code - ISO 12176-4

QMS according to ISO 9001

Pipes to be marked as per standards

Fully documented shipments inc. 3rd party

Offer full package of jointing tools

Offer on site support for large projects

Provide practical training for contractors and end users

The Quality Plan

A document that describes the standards, quality practices, resources and processes related to a particular product or activity

This is the key document within the QMS that describes how the different elements fit together to deliver a quality product or service
Quality plans related to manufacturing processes contain a lot of information concerning what inspection and testing is undertaken to assess whether the product is conforming to the required standards and manufacturing requirements

If the manufacturer is a member of a conformity assessment scheme then the contents of the quality plan must, as a minimum, comply with the requirements of the scheme.



Diagram representing a typical quality plan for a pipe or fitting manufacturer

TT: Type Tests
BRT: Batch Release Tests
PVT: Process Verification Tests
AT: Audit Tests

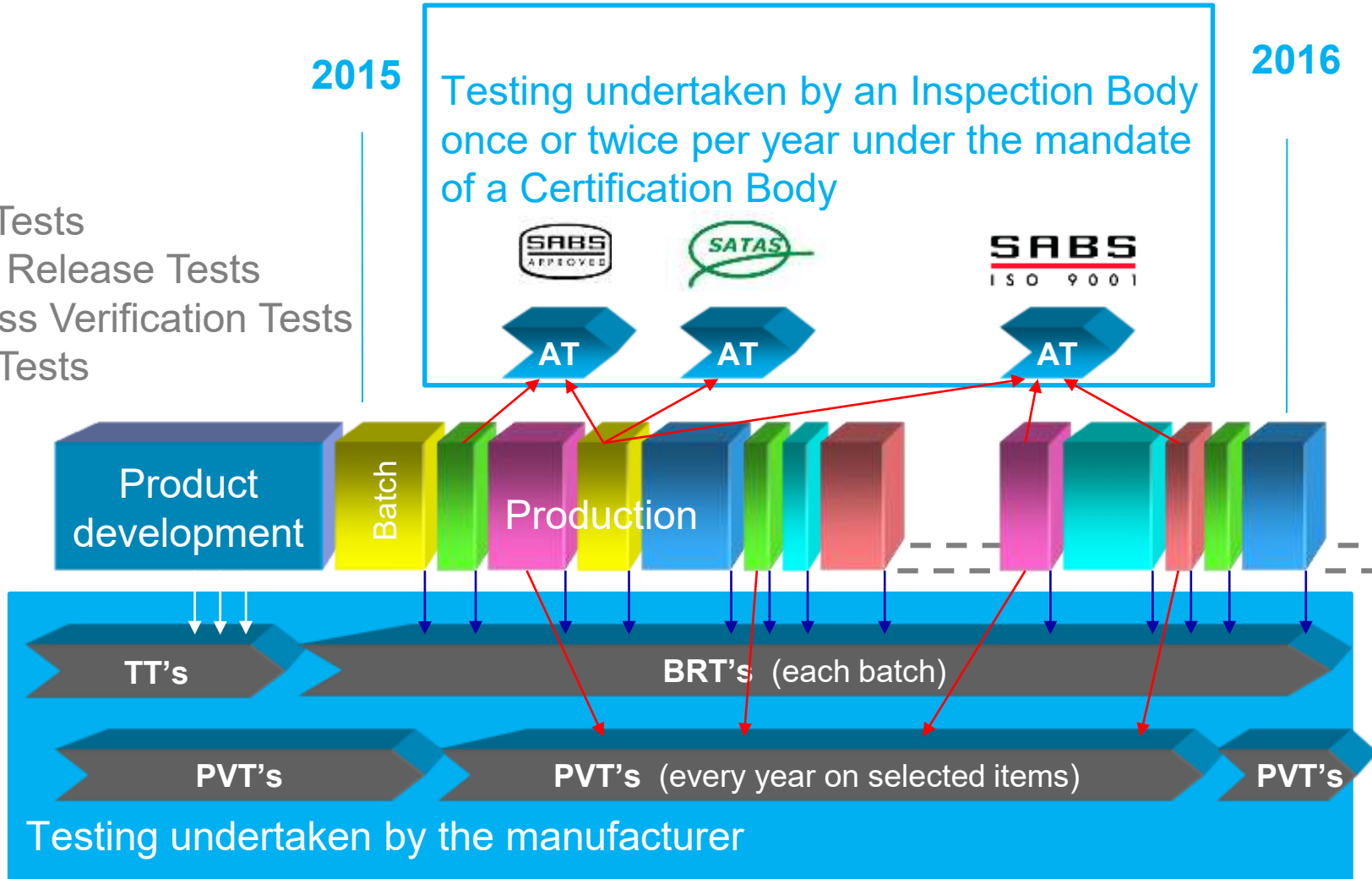

The key elements of a sustainable quality management system

- Simplify and minimize the number of procedures as far as practical whilst complying with standards and ensuring quality
- Only employ procedures and systems that add value to the process and keep them as simple as is practical
- Encourage the use of industry organizations that promote consistently high-quality products through 3rd party testing, such as the PE100+ Association/ SAVA / SAPPMA / IFPA / JASWIC
- Encourage the use of conformity assessment schemes and quality marks as these provide a simple and quick means for end users to determine whether a pipe or fitting complies with relevant standards – eg. PE100+ Association/ SAVA / SAPPMA / IFPA / JASWIC
- Encourage continuity between the quality systems of different stakeholders by referring to common standards and procedures (**Procurement Process**)– avoid the weakest link !

Guidance for Assessment

PD CEN/TS 12201-7:2014



BSI Standards Publication

**Plastics piping systems
for water supply, and for
drainage and sewerage
under pressure —
Polyethylene (PE)**

Part 7: Guidance for the assessment
of conformity

PD CEN/TS 1555-7:2013



BSI Standards Publication

**Plastics piping systems for the
supply of gaseous fuels —
Polyethylene (PE)**

Part 7: Guidance for the assessment
of conformity

in correct as of 09/05/2014 © The British Standards Institution 2014

HDPE /PVC/PP Pipe and Components

Introduction

Figure 1 and Figure 2 are intended to provide general information on the concept of testing and organization of those tests used for the purpose of the assessment of conformity. For each type of test, i.e. type testing (TT), batch release test (BRT), process verification test (PVT), and audit test (AT), this part of EN 12201 details the applicable characteristics to be assessed as well as the frequency and sampling of testing.

A typical scheme for the assessment of conformity of compounds, pipes, fittings, valves, joints or assemblies by manufacturers is given in Figure 1.

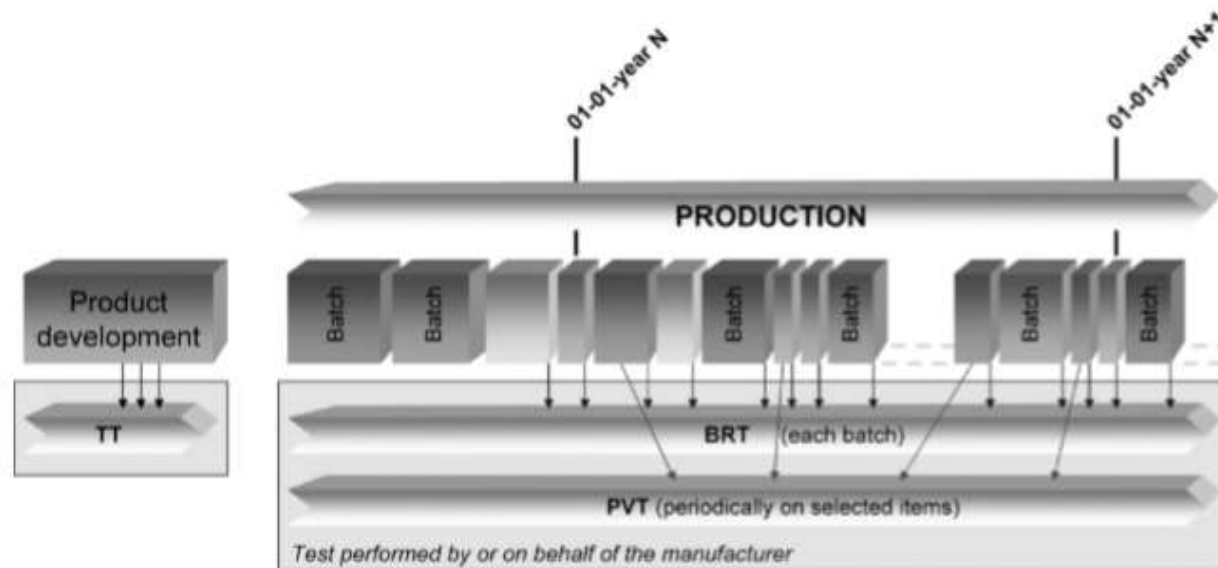

Figure 1 — Typical scheme for the assessment of conformity by a manufacturer

Quality Plans for Assessment of Conformancy

A typical scheme for the assessment of conformity of compounds, pipes, fittings, valves, joints or assemblies

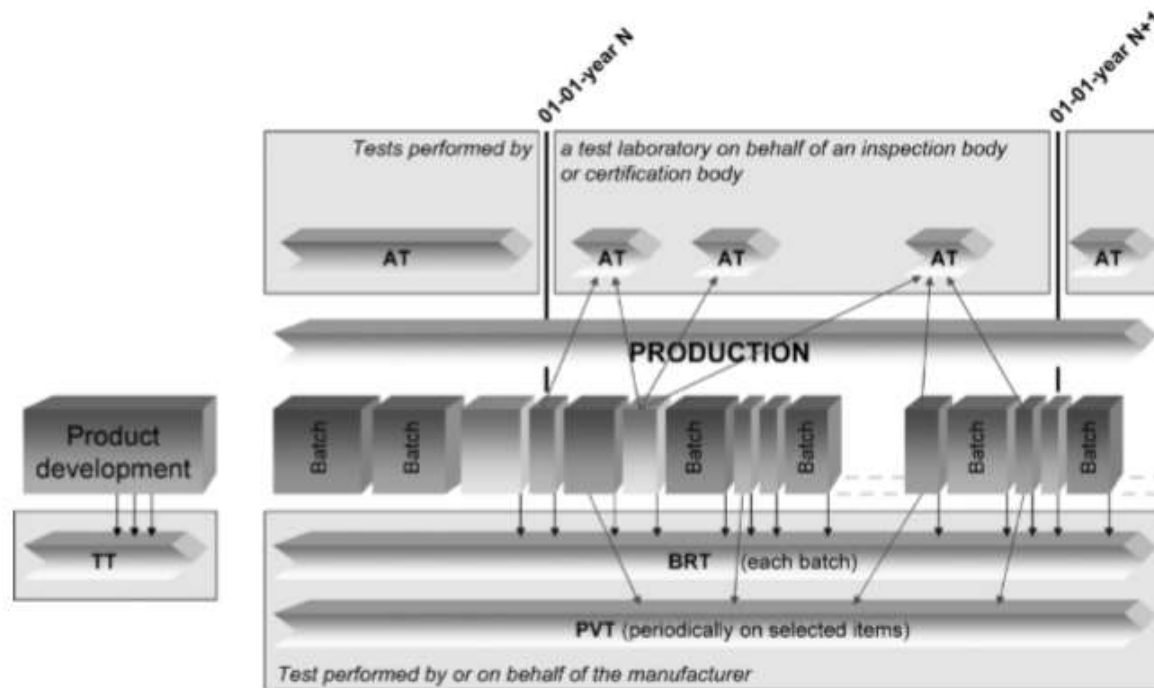

Figure 2 — Typical scheme for the assessment of conformity by a manufacturer, including certification

The present and then the future

This first edition cancels and replaces ISO 4422-1:1996, which has been technically revised.

ISO 1452 consists of the following parts, under the general title *Plastics piping systems for water supply and for buried and above-ground drainage and sewerage under pressure — Unplasticized poly(vinyl chloride) (PVC-U)*:

- *Part 1: General*
- *Part 2: Pipes*
- *Part 3: Fittings*
- *Part 4: Valves*
- *Part 5: Fitness for purpose of the system*

Guidance for the assessment of conformity is to form the subject of a part 7.



**THIRD PARTY
LAB TESTED**

SAPPMA
australian sheet plastic pipe manufacturers association

New draft Standards under development

Assessment of conformity of plastics piping systems for the rehabilitation of existing pipelines — Part 1: Polyethylene (PE) material

ISO/TS 23818-1:2019(E)

The format of the three Technical Specifications is in line with Technical Specifications for assessment of conformity to other system standards, apart from presenting the detailed requirements for Inspection and Testing in two annexes, for non-pressure applications and pressure applications (where applicable) respectively.

The format is schematically represented in Figure 1.

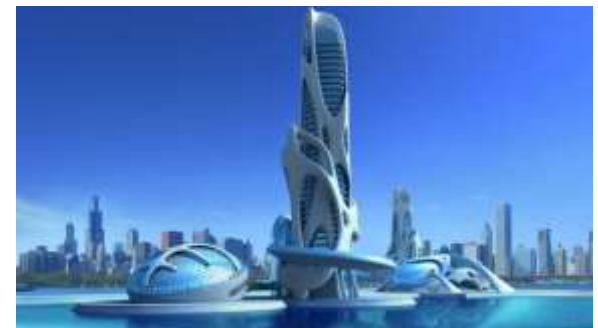
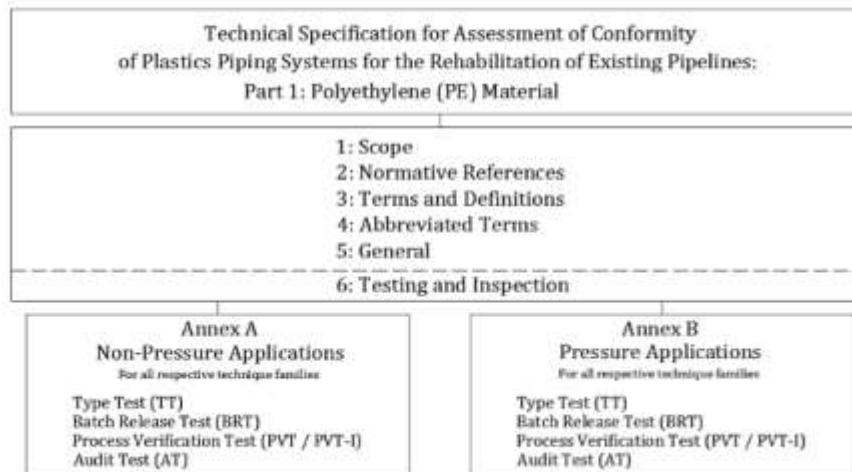

Figure 1 — Format of the Technical Specifications for Conformity Assessment

Questions and Answers

